



PRODUCT  
CATALOGUE  
2021



**SPECIALIST CONTROL SOLUTIONS**  
[www.cromptoncontrols.co.uk](http://www.cromptoncontrols.co.uk)

# This is Crompton Controls

Welcome to a heritage spanning 130 years supplying outstanding controls and system solutions.



## Standard & Bespoke Starters

We've made industrial electric motor starters for generations and are still N°1 in what we do with a huge installed base and the widest range from a single UK supplier.

What is standard for us is often not even available from others or at the very least not available in the lead time we can provide.

Our experienced Sales & Technical Support Teams are readily contactable to help you select from our massive back catalogue or design a bespoke starter to suit your exact specification from special control features to enhanced connectivity or any other custom solution.

Get off to the right start with the best known electric motor starter manufacturer in the UK!

## Control Panel Design & Build

If you like our starter's, you'll love our main courses! Custom built control panels.

A massive and rapidly growing sector of our business with a professional tendering service and dedicated project engineers providing extensive control panel knowledge, experience and technical support.

With full AutoCAD design, quick drawing turnaround and a highly skilled production team, dedicated to hitting client deadlines, you really can rely on us for all your special control panel needs. From motor and machine panel control to fan and pump operation, variable speed drive and power changeover to fully functional building management system control panels.

Whatever your specification, we'll provide the definitive solution!

## Components & Peripherals

Whether you're looking inside or outside of your box we have an extensive portfolio of panel components and peripheral control equipment.

Whether Compton own branded or in conjunction with our select international partners and exclusive UK distribution deals we can supply an impressive and comprehensive range of products.

From internal panel controllers, modules, switchgear and panel door mounted devices, to external panel sensors, detectors and indicators, electric motors, mechanical drive transmission equipment, variable speed inverters and much, much more!

All available through one of the largest distribution networks in the UK!

'...We Design, Manufacture, Distribute & Support with a professional yet personal touch & a core value to be as easy to deal with as possible so that you can trust us to look after your business with minimum fuss..!'



**DESIGN**  
AutoCAD - Expert Project Engineers



**MANUFACTURE**  
Long History of Technical Excellence



**DISTRIBUTE**  
Nationwide Partner Network

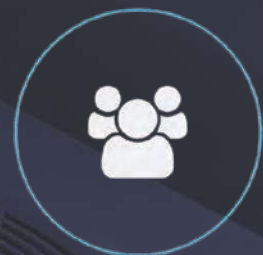

**SUPPORT**  
Technical Guidance, Sales & Service

**Power Transmission,  
Industrial Controls,  
Advanced Panel Meters,  
Control Panels & Peripheral  
Equipment** (Page 4 to 13)

Section 1

**Starters, Enclosures & Easy  
Speedy** (Page 14 to 21)

Section 2

**DC Injection Brake Systems**  
(Page 22 to 25)

Section 3

**Hazardous Area Starters  
& Controls** (Page 26 & 27)

Section 4

**Contactors & Accessories**  
(Page 28 to 33)

Section 5

**Panel Components, Control  
Stations & Electronic Timer  
Relays** (Page 34 to 39)

Section 6

**Shaft Power Monitors & Soft  
Starters** (Page 40 to 43)

Section 7

**Variable Speed Inverter  
Drives** (Page 44 to 59)

Section 8

**Technical Information**  
(Page 60 & 61)

Section 9

**Slat Wall Displays, Spools,  
Switches, Lockout and  
Conditions of Sale**  
(Page 62 & 63)

Section 10

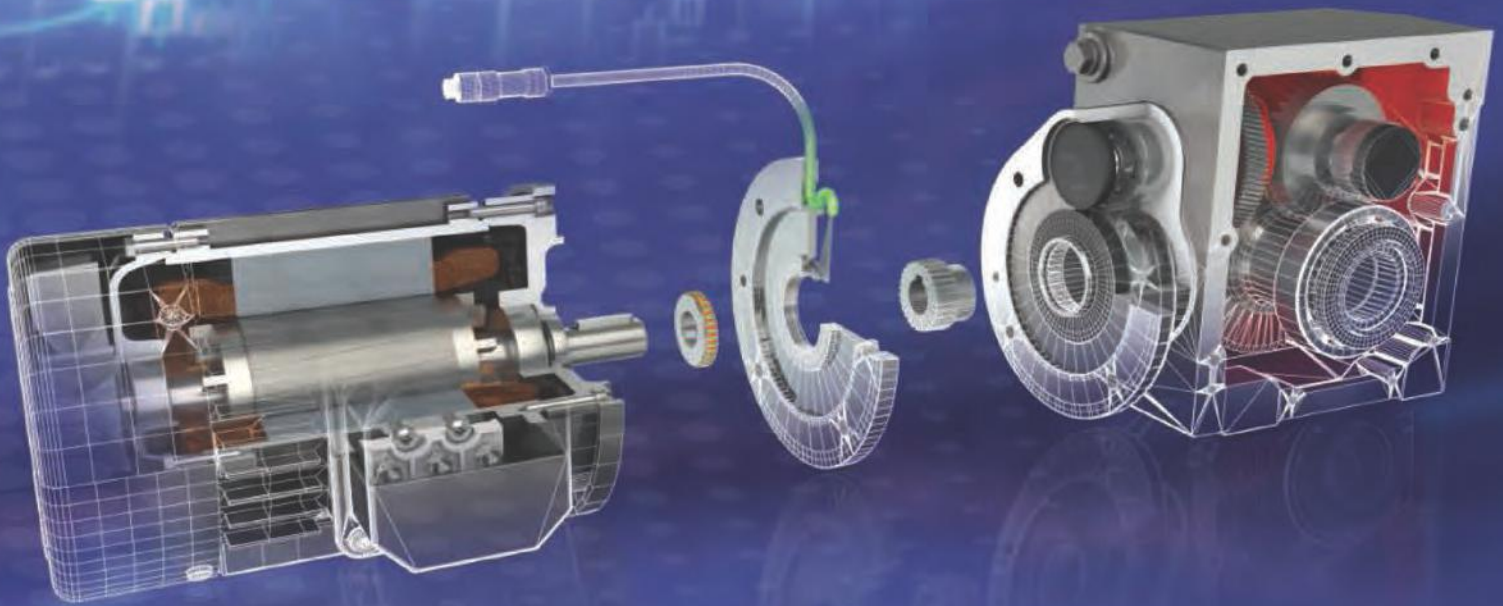

## TRANSMISSION WITH CONTROL

### High Quality Power & Control Products



- BEGE (Mini) Helical Gear Motors
- BEGE Hypoid Gear Motors
- STRÖTER Helical Bevel Gear Motors
- STRÖTER Variable Speed Gear Motors
- Drum Motors
- MIG Encoders
- Aluminium or Stainless Steel...

For Sales & Support of the complete  
**BEGE** and **STRÖTER** product ranges |

01924 368251

# Control Your Transmission..!

## Standard Geared Motors

to fully customised **Products & Drive Solutions**

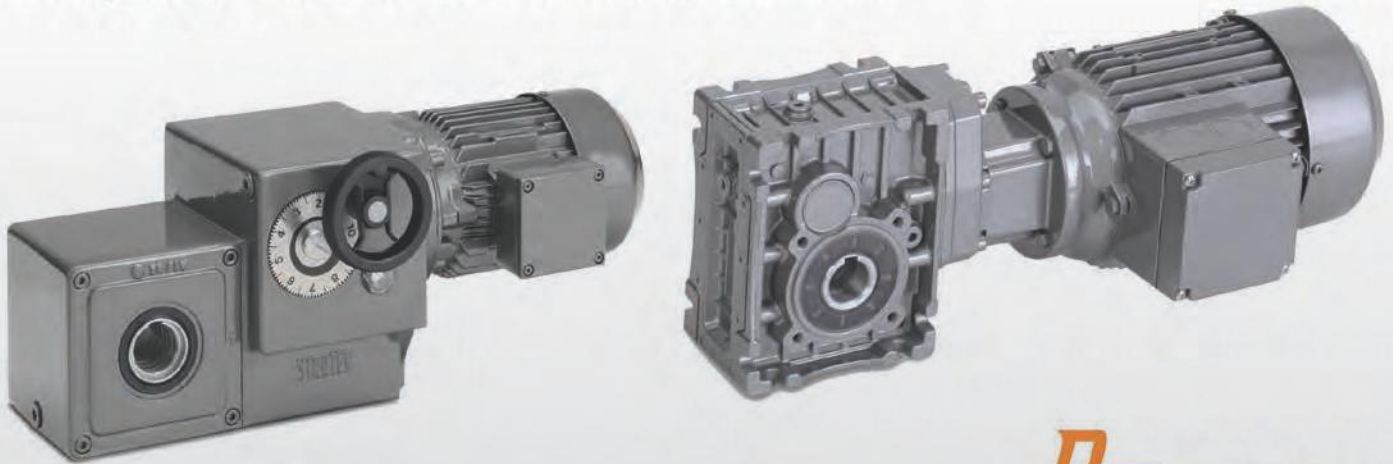

Crompton Controls are the NEW UK Distribution Partner for



**EAT-N**  
X10

# Sounder Beacons

For Industrial Alarms & Signalling..!

Standard Features:

- 10 Year Warranty
- IP69/IK08
- UV fade resistant
- Up to 4 stage alarm
- 4 Body Colours
- 6 LED lens colours
- 3 Voltage variants



Simple 4-Step Product Selection... ..the choice is yours.

1. Size: Mini 100dB(A), Midi 110dB(A) or Maxi 120dB(A)
2. Housing Colour: White, Light Grey, Dark Grey or Red
3. Voltage: 10-60V DC, 10-30V AC or 115/230V AC
4. LED Beacon Colour: Red, Amber, Magenta, Green, White or Blue

 Call us **NOW** for Technical Help and Pricing..!

The most customizable,  
easy-to-use panel meter  
line on the market.



# Advanced Panel Meters

Cutting Edge, State of the Art Technology

- Smarter - Safer - Easier
- The modern digital monitoring solution
- Programmable dynamic colour backlighting
- High visibility status from distance
- For all your critical parameters

 Call us **NOW** for Technical Help and Pricing..!

# We've got you covered with the APM family!

Unique dynamic backlighting and starburst messaging, instant alarm status alerts, scale and range are fully customisable through plug and play software. IoT ready, get your data anywhere.



NORMAL RANGE



OPTIMAL RANGE



OUTSIDE RANGE



## AMP METER

A general purpose meter for measuring AC & DC current for applications including control panels and power supplies.

- Auto-detects AC or DC input
- Measures 5A direct or up to 10,000A with a current transformer
- 1.0% accuracy



## VOLT METER

A general purpose meter for measuring mains voltage for applications including control panels and power supplies.

- Auto-detects AC or DC input
- Measures up to 600V DC/AC
- 1.0% accuracy



## CT METER

For measuring AC current in conjunction with an external CT for applications including motor control, heating control and industrial power supplies.

- Use with external current transformer
- Monitors AC currents up to 10,000A in conjunction with a current transformer
- 0.5% accuracy



## FREQUENCY METER

For measuring frequency and speed for applications including control panels, industrial applications and aviation.

- Accurately measures DC pulses from a sensor
- Supports a wide range of inputs between 2-400Hz
- 0.5% accuracy



## M2 METER

All-in-one meter that can be configured to measure amps, voltage or frequency for applications including switchgear and power control centers.

- 100-240V AC mains powered
- No additional power supply required
- 40-segment bar graph scale



## PROCESS METER

A specialized meter for process control applications including variable speed drives, flow and pressure transducers, and linear and non-linear sensors.

- 20 point non-linear conversion
- Can measure 0-10V DC or 0-50mA
- 0.1% accuracy across the input range



## SHUNT METER

A specialized meter for measuring DC current in conjunction with an external shunt for applications including marine, leisure and material handling.

- For use with shunts up to 1000mV
- High resolution 0-1V DC input
- Measures to 0.1% accuracy of the signal or 0.5mV (whichever is greater)



## RATE METER

A specialized meter for measuring speed, rate and flow for applications including motor speed, pump controls and production line monitoring.

- Process time measurement
- Wide input range of 0-60kHz
- 0.1% accuracy

# POWER METER



A universal power meter for single-phase, split-phase and 3-phase power monitoring applications.

- Works with potential and current transformers
- Modbus® RTU included
- 4 alarm setpoints



# APM MAX



## New APM MAX meter

The APM MAX meters large 81.5mm x 66mm LCD screen the has a two-line display, programmable scale and alarm set-points with colour-changing, full colour RGB backlight for instant alerts. An all-in-one meter with endless configuration options, it features digital and analogue outputs and serial MODBUS® RTU as standard (ethernet MODBUS® also available).

- **APM-MAX-M21:** for high voltage applications; configurable as an ammeter, volt-meter, frequency meter or power monitor (Watts, VA & Power Factor).
- **APM-MAX-M23:** for low voltage applications; configurable as a process meter or to be used in conjunction with a shunt.

## DIMENSIONS

### APM Meter Series

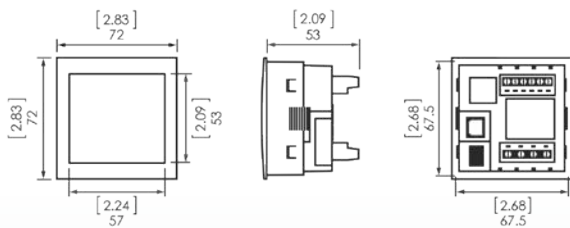

#### MECHANICAL

Dimensions: 72mm x 72mm x 53mm | 2.83" x 2.83" x 2.09"  
Cutout: 68mm x 68mm | 2.68" x 2.68" as per DIN43700/IEC61554

### APM Power Meter

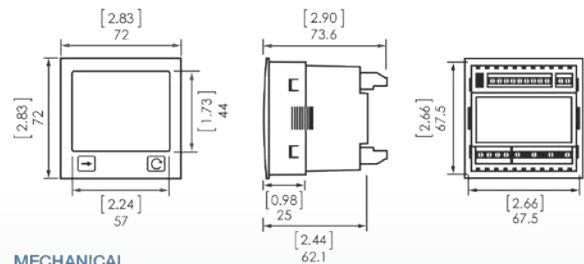

#### MECHANICAL

Dimensions: 72mm x 72mm x 74mm | 2.83" x 2.83" x 2.90"  
Cutout: 68mm x 68mm | 2.68" x 2.68" as per DIN43700/IEC61554

### APM MAX Meter

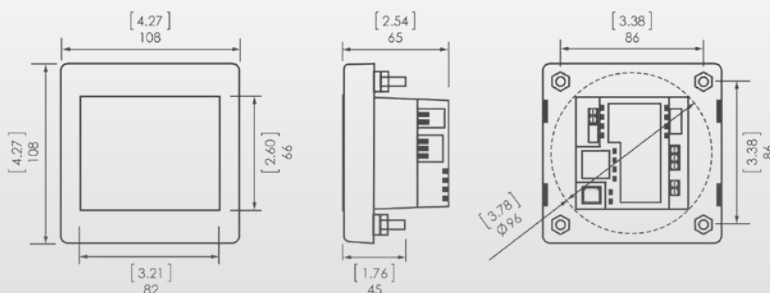

#### MECHANICAL

Dimensions: 108.4mm x 108.4mm x 64.5mm | 4.268" x 4.268" x 2.54"  
Cutout: Square: 68mm x 68mm | 2.7" x 2.7" | Circle Diameter: 96mm | 3.8"



# Advanced Panel Meters

Our Complete Listed Range



Reference	Description	List Price £
APM-AMP-CNO	APM Amp Meter: Negative LCD w/outputs	64.90
APM-AMP-CPO	APM Amp Meter: Positive LCD w/outputs	64.90
APM-CT-CNO	APM CT Meter: Negative LCD w/outputs	64.90
APM-CT-CPO	APM CT Meter: Positive LCD w/outputs	64.90
APM-FREQ-CNN	APM Frequency Meter: Negative LCD	52.50
APM-FREQ-CNO	APM Frequency Meter: Negative LCD w/outputs	64.90
APM-FREQ-CPN	APM Frequency Meter: Positive LCD	52.50
APM-FREQ-CPO	APM Frequency Meter: Positive LCD w/outputs	64.90
APM-M2-CNO	APM M2: Amp, Volt and Frequency Meter	64.90
APM-M2-CPO	APM M2: Amp, Volt and Frequency Meter	64.90
APM-PROC-CNO	APM Process Meter: Negative LCD w/outputs	89.60
APM-PROC-CPO	APM Process Meter: Positive LCD w/outputs	89.60
APM-RATE-CNO	APM Rate Meter: Negative LCD w/outputs	71.10
APM-RATE-CPO	APM Rate Meter: Positive LCD w/outputs	71.10
APM-SHUNT-CNO	APM Shunt Meter: Negative LCD w/outputs	89.60
APM-SHUNT-CPO	APM Shunt Meter: Positive LCD w/outputs	89.60
APM-VOLT-CNO	APM Volt Meter: Negative LCD w/outputs	64.90
APM-VOLT-CPO	APM Volt Meter: Positive LCD w/outputs	64.90
APM-MAX-M21-PU-4R	APM MAX: High Voltage w/Modbus RTU	187.50
APM-MAX-M23-PU-4R	APM MAX: Low Voltage w/Modbus RTU	187.50
APM-MAX-M21-PU-4B	APM MAX: High Voltage w/Modbus RTU, TCP/IP	210.10
APM-MAX-M23-PU-4B	APM MAX: Low Voltage w/Modbus RTU, TCP/IP	210.10
APM-PWR-CPO	APM 3-Phase Power Meter w/Modbus RTU	140.10

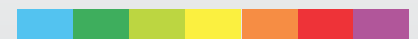

 Call us **NOW** for Technical Help and Pricing..!

## Panel Engineering you can Trust

Crompton Controls is a leading control panel specialist in the UK. Providing flexible and economic solutions from design to manufacture within the Building Management Systems (BMS), Motor Control, Switchgear and Lighting design sectors. Crompton Controls delivers a wealth of experience to our strong and growing customer base.

It's the attention to detail and commitment to excellence that truly makes our control panel offering really stand out as something very special. Within the control panel and BMS sectors, we have gained a reputation for being one of the best in control panel build and our expert engineers have decades of panel design and build experience. This same team of engineers are dedicated from tender through to completion and sign off.

At Crompton Controls we utilise an extremely user friendly Auto-CAD system, which has been designed spe-

cifically to meet the exacting requirements of the industry and is an integral part of our operation in offering top quality solutions throughout all of our control panel design.

Ranging from small operator workstations to large multi-bay suites, our control panels are built to a wide range of protection categories with full certification and documentation.

Providing a full range of our own Crompton branded control components, along with having close strategic partnerships with many industry leading brands such as Annicom, Eldon, Yaskawa, Crompton Greaves and Emotron just to name a few, enables us to compete at all levels to fulfil end customer requirements from a simple panel build through to a total, cutting edge project solution.



## To compliment our panel build we offer Fast, Accurate, High Quality Precision Engraving & Cutting with repeatable quality..!

The engraving system uses a state of the art laser plotter that can be deployed for either laser engraving or as a laser cutting machine.

The software package enables us to download images such as company logos to high resolution photo images, CAD files and transfer them directly onto any material.

In addition it has the ability to cut the most complex design with amazing repeatable accuracy whilst handling high volume production.



Contact our Projects Team now

[sales@cromptoncontrols.co.uk](mailto:sales@cromptoncontrols.co.uk) / **01924 368251**

# Why choose Crompton for your **Control Panels**

- **Professional Tendering Service** - We aim for a 24hr quotation turnaround
- **Dedicated Project Engineer** - From initial design to client handover
- **Extensive BMS & Panel Knowledge, Experience & Technical Support**
- **Professional CAD Design Service** - Ensures quick turnaround on drawings
- **Full Health Check** - On panel completion prior to despatch
- **Quality Build** - To the latest ISO 9001 (2015) compliance
- **Site Work** - For panel modifications / retrofit
- **Professional Motivated Production Team** - Dedicated to hitting deadlines



Control Panels / BMS Panels / VSD Panels / Lighting KNX Panels / Automatic Changeover Panels & Associated Control & BMS Components & Peripherals...

# AXIO



## Control & BMS Peripheral Equipment



Comprehensive range including:

- Temperature & Humidity Sensors
- Relay Modules
- Input/Output Modules
- Thyristor Power Controllers
- Air & Liquid Pressure Sensors
- Gas & Smoke Detectors

**DID YOU KNOW**  
we now supply all  
of your Control &  
BMS Peripherals..?

*In Association with Annicom*

**ANNICOM** **AXIO**  
YOUR PARTNER IN TECHNOLOGY  
Crompton Controls In Partnership

 Call us **NOW** for Technical Help and Pricing..!

## Input / Output & Relay Modules

Our wide range of Input/Output & Relay Modules will allow you to convert inputs and provide all the I/O signalling and control requirements for your application automatically within your project or building.

These modules are perfect for multiplexing, alarm management, boiler sequencing, voltage control and any other application where I/O control is needed. They add I/O and functionality to your project and are designed to be used in a wide range of buildings and HVAC applications.

- Compact Size
- Din rail mount
- Rising clamp terminals
- 24 VAC/DC supply
- Large range of types



## Temperature Sensors

Products, that we draw on 30 years' of experience in designing, developing and manufacturing high-quality environmental controls to bring you a wide range of temperature sensors. Have a look through our range or call us.

- Stainless Steel probes on Duct and Immersion types with IP65 Enclosures
- IP68 Flying lead available
- Thimble and Button in various finishes
- Vast range of Sensor types
- Transmitters for all housing styles (not button)
- High Accuracy
- 3 year warranty



## Air and Liquid Pressure

This range of controls offer both switches and transmitters for liquid and air. They offer flow and indication in HVAC application to ensure correctly functioning systems. Cost effective pressure switches are available for raising alarms, fan proving and flagging to the BMS when a filter needs changing to maintain air flow efficiency.

- LPCB approved switches available
- Static and differential types
- Highest quality materials used
- Up to 42 bar in liquid range
- Multi range air transmitter available
- 3 year warranty



## Thyristor Power Controllers

A range of duct and fan coil heater power controllers with high reliability, small size to power ratio suitable for controlling loads from an analogue signal.

- No additional heat sinks or RFI filters required
- Din Rail and Panel mount types
- Small footprint save panel space
- Single and three phase versions
- Over temperature sensor on all units.
- Zero volt switching
- Enclosure versions available.
- Range covers 2-105kW



Selected best sellers from our brand new partnership range  
Please refer to our separate [Control & BMS Peripherals Catalogue](#) for full product details...

# SERIES 3000



## How's this for **Starters..?**

■ ■ ■ ■ BOX SIZE Colour Chart - See Page 18

- Direct On Line / Star Delta
- DOL Reversing / 1Ph Series Parallel
- 2 Speed Dual Wound / 2 Speed Pole Change
- DOL Duty Standby / DOL Fanshaker
- DOL Flush Mounted
- Manual Motor Starters

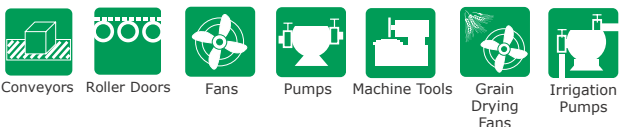

## Direct-on-Line Standard Starters

**Features:**

- Robust Enclosure - Sheet Steel IP55
- Surface Mounting Type: 3DL
- Built in Start/Stop Reset Push Buttons
- Single Phase or Three Phase
- Standard Coil Voltages: 50/60Hz
- Hand reset thermal overloads
- Colour RAL7035 Light Grey
- 24V, 48V, 110V, 230V, 400V, 440V and more
- Provision for remote control



Max FLC (415V 3ph)	kW	Approx. (HP)	Without Isolator & Mains Fuses Reference	List Price £	With Isolator Reference	List Price £	With Isolator & Mains Fuses Reference	List Price £
12	5.5	(7.5)	3DL1--S	82.50	3DL1--I	184.00	3DL1--F	238.50
18	7.5	(10)	3DL2--S	99.50	3DL2--I	198.00	3DL2--F	292.00
25	11	(15)	3DL3--S	107.50	3DL3--I	202.50	3DL3--F	318.50
30	15	(20)	3DL4--S	149.00	3DL4--I	230.00	3DL4--F	359.50
40	18.5	(25)	3DLA5--S	252.50	3DLA5--I	374.00	3DLA5--F	457.00
50	26	(35)	3DL5--S	307.00	3DL5--I	478.00	3DL5--F	647.00
65	30	(40)	3DL6--S	382.50	3DL6--I	529.50	3DL6--F	696.50
80	37	(50)	3DL07--S	478.00	3DL07--I	649.00	3DL07--F	1,009.50
100	55	(75)	3DL08--S	629.00	3DL08--I	961.00	3DL08--F	1,407.50
140	75	(100)	3DL09--S	812.00	3DL09--I	1,373.50	3DL09--F	1,823.00
180	90	(125)	3DL10--S	1,149.00	3DL10--I	1,707.50	3DL10--F	2,038.50
200	110	(150)	3DL11--S	1,218.50	3DL11--I	1,903.00	3DL11--F	2,263.00
220	132	(175)	3DL12--S	1,304.50	3DL12--I	2,058.50	3DL12--F	2,695.50

Where a starter is required without overload, deduct the appropriate overload price as follows:

**Overload:**  
 Up to 18 amps **£37.00**  
 19 to 25 amps **£40.50**

Contactor Coil Voltage & Hz			
Dual 50 / 60Hz		50Hz Only	
Standard	Voltage	Special	Voltage
A	110		
C	230		
D	24		
E	400		
F	440		
I	48		
S	480	P	208

Overload Range				
Code	I <sub>FLC</sub>	Star Delta	Overload Relay	110V Contactors
X	0.16 - 0.25A		CR09/0.25	CC09 to CC32
A	0.25 - 0.4A		CR09/0.4	CC09 to CC32
B	0.4 - 0.63A		CR09/0.63	CC09 to CC32
D	0.63 - 1.0A		CR09/1	CC09 to CC32
E	1.0 - 1.6A		CR09/1.6	CC09 to CC32
F	1.6 - 2.5A	2.7 - 4.3A	CR09/2.5	CC09 to CC32
G	2.5 - 4.0A	4.3 - 6.9A	CR09/4	CC09 to CC32
H	4.0 - 6A	6.9 - 10.4A	CR09/6	CC09 to CC32
J	5.5 - 8A	9.5 - 13.8A	CR09/8	CC09 to CC32
K	7.0 - 10A	12 - 17A	CR09/10	CC09 to CC32
L	10 - 13A	17 - 22A	CR12/13	CC09 to CC32
M	13 - 18A	22 - 31A	CR16/18	CC09 to CC32
N	18 - 25A	31 - 43A	CR25/25	CC09 to CC32
C	23 - 32A	39 - 55A	CR32/32	CC25 to CC32
Q	28 - 40A	48 - 69A	CR32/40	CC25 to CC32
R	23 - 32A	39 - 55A	CR40/32	CC40 to CC65
S	30 - 40A	51 - 69A	CR40/40	CC40 to CC65
T	38 - 50A	65 - 86A	CR63/50	CC40 to CC65
U	48 - 57A	83 - 98A	CR63/57	CC40 to CC65
V	57 - 66A	98 - 114A	CR63/66	CC40 to CC65
W	63 - 80A	109 - 138A	CRA80/80	CC40 to CC80
P	80 - 93A	138 - 161A	CRA80/93	CC40 to CC80

Extra Features Suffix Codes	
Code	Description
01	Stop/Reset Only
02	Press to Run
03	Hand/Off/Auto Selector
04	Ammeter
05	Separate Control Circuit
06	Control Transformer
07	Line to Neutral Control
10	Single Phase Mains Wiring
11	Single Phase & Stop Reset
12	Single Phase & Press to Run
13	Single Phase & Hand/Off/Auto
14	Single Phase & Ammeter

Y Thermister Protection  
 Z Without Overload Fitted (Wiring for loose O/L to be fitted)

Higher Thermal Overload Ranges available on request.  
 Note: For how to code a Standard Starter see page 54



3DL1ELS

## Star Delta Standard Starters

**Features:**

- Robust Enclosure - Sheet Steel IP55
- Surface Mounting Type: 3SD
- Built in Start/Stop Reset Push Buttons
- Three Phase
- Standard Coil Voltages: 50/60Hz
- Hand reset thermal overloads
- Wye Delta Connected
- 24V, 48V, 110V, 230V, 400V, 440V and more
- Provision for remote control

Max FLC (415V 3ph)	Approx. kW	Approx. (HP)	Without Isolator & Mains Fuses		With Isolator		With Isolator & Mains Fuses				
			Reference	List Price £	Reference	List Price £	Reference	List Price £	(Interior Only) List Price £		
21	11	(15)	3SD1--S	320.50	(277.50)	3SD1--I	383.50	(342.50)	3SD1--F	432.00	(391.00)
30	15	(20)	3SD2--S	332.00	(290.00)	3SD2--I	391.00	(353.00)	3SD2--F	457.00	(399.50)
43	22	(30)	3SD3--S	385.50	(342.50)	3SD3--I	532.50	(483.50)	3SD3--F	722.50	(694.50)
55	30	(40)	3SD4--S	500.00	(457.00)	3SD4--I	720.50	(675.50)	3SD4--F	843.50	(791.00)
69	37	(50)	3SDA5--S	637.50	(593.50)	3SDA5--I	853.00	(807.50)	3SDA5--F	1,076.50	(1,027.00)
85	45	(60)	3SD05--S	665.00	(616.50)	3SD05--I	880.00	(831.00)	3SD05--F	1,108.00	(1,057.50)
98	55	(75)	3SD06--S	878.00	(825.50)	3SD06--I	1,276.00	(1,237.00)	3SD06--F	1,508.00	(1,467.00)
138	75	(100)	3SD07--S	1,072.50		3SD07--I	1,504.00		3SD07--F	1,951.00	
160	90	(125)	3SD08--S	1,175.00		3SD08--I	1,831.50		3SD08--F	2,277.50	
208	110	(150)	3SD09--S	1,418.00		3SD09--I	2,100.50		3SD09--F	2,529.50	
250	150	(175)	3SD10--S	2,179.00		3SD10--I	3,750.00		3SD10--F	4,596.00	
310	185	(250)	3SD10--S	2,179.00		3SD10--I	3,750.00		3SD10--F	4,596.00	
346	200	(287)	3SD11--S	2,263.00		3SD11--I	3,877.00		3SD11--F	4,804.00	
380	220	(300)	3SD12--S	2,400.50		3SD12--I	3,944.00		3SD12--F	5,009.00	

3DL1ELI

## Direct-on-Line Reversing Standard Starters

**Features:**

- Robust Enclosure - Sheet Steel IP55
- Surface Mounting Type: 3DR
- Hand reset thermal overloads
- Single Phase or Three Phase
- Standard Coil Voltages: 50/60Hz
- Built in Forward/Stop Reset/Reverse Push Buttons
- Provision for remote control
- Colour RAL7035 Light Grey
- 24V, 48V, 110V, 230V, 400V, 440V and more



Max FLC (415V 3ph)	Approx. kW	Approx. (HP)	Without Isolator & Mains Fuses		With Isolator		With Isolator & Mains Fuses	
			Reference	List Price £	Reference	List Price £	Reference	List Price £
12	5.5	(7.5)	3DR1--S	164.00	3DR1--I	247.00	3DR1--F	335.00
18	7.5	(10)	3DR2--S	168.50	3DR2--I	251.00	3DR2--F	340.50
25	11	(15)	3DR3--S	252.50	3DR3--I	331.00	3DR3--F	532.50
30	15	(20)	3DR4--S	363.50	3DR4--I	411.00	3DR4--F	611.50

Not available as 480/1150 - For reversing Starters above 15kW - P.O.A. Available as Up/Stop/Down plus other text combinations on request

## Direct-on-Line Fan Shaker - For Dust Extraction Systems

**Features:**

- Robust Enclosure - Sheet Steel IP55
- Surface Mounting Type: 3FS
- Overload current ranges: 0.16 to 25amps
- Timer Single Unit - Run Down Time Adjustable to 2 minutes - Shake time adjustable to 1 minute
- Single Phase or Three Phase
- Standard Coil Voltages: 50/60Hz
- Colour RAL7035 Light Grey
- 24V, 48V, 110V, 230V, 400V, 440V and more
- Two Motor D-O-L

Max FLC (415V 3ph)	Approx. kW	Approx. (HP)	Without Isolator		With Isolator		With Isolator & Fuses	
			Reference	List Price £	Reference	List Price £	Reference	List Price £
12	5.5	(7.5)	3FS1--S	278.50	3FS1--I	378.50	3FS1--F	437.00
18	7.5	(10)	3FS2--S	284.00	3FS2--I	389.00	3FS2--F	485.50
25	11	(15)	3FS3--S	327.00	3FS3--I	432.00	3FS3--F	528.50



**\* Standard Offer Includes:**  
Fan Contactor and Overload, Shaker Contactor and Timer For Low Voltage Fan Shaker Starters please consult our Design Engineers.

Shaker Overload up to 1.6 amps add - 35.00  
Neon - Lamp - Shaker Tripped up to 230V - P.O.A.  
Emergency Stop - P.O.A.  
Any combination on request - P.O.A.



3FS1EKS

**Options - Timer Only:**

Reference	Voltage	List Price £
FS2 400V	400V	121.00
FS2 230V	230V	121.00
FS2 110V	110V	121.00

## Direct-on-Line Flush Mounted - Unique Design

**Features:**

- Robust Enclosure - Sheet Steel IP55
- Single Phase or Three Phase
- Standard Coil Voltages: 50/60Hz
- Pressed steel lid, formed sheet steel base
- Flush Mounting Type: 3DF
- 24V, 48V, 110V, 230V, 400V, 440V and more
- Overload current ranges: 0.16 to 18amps



Max FLC (415V 3ph)	Approx. kW	Approx. (HP)	All Steel Enclosure	
			Reference	List Price £
12	5.5	(7.5)	3DF1--S	137.50
18	7.5	(10)	3DF2--S	147.50

Flush Mounting Starters are designed to fit into small machine frameworks and castings to provide a neat outer operator control station with all fixing and cabling components hidden away inside



3DF1CLS10

## Manual Motor Starters

Reference	Description	List Price £
CCMS0.16	Manual motor starter overload 0.1-0.16	77.50
CCMS0.25	Manual motor starter overload 0.16-0.25	79.00
CCMS0.4	Manual motor starter overload 0.25-0.40	79.00
CCMS0.63	Manual motor starter overload 0.40-0.63	79.00
CCMS1	Manual motor starter overload 0.63-1	87.50
CCMS1.6	Manual motor starter overload 1-1.6	87.50
CCMS2.5	Manual motor starter overload 1.6-2.5	87.50
CCMS4	Manual motor starter overload 2.5-4	87.50
CCMS6.3	Manual motor starter overload 4-6.3	87.50
CCMS10	Manual motor starter overload 6.3-10	96.50
CCMS16	Manual motor starter overload 10-16	96.50
CCMS20	Manual motor starter overload 16-20	105.50
CCMS25	Manual motor starter overload 20-25	121.00
CCGE1	IP55 Enclosure	25.00
CCUN110V	Under voltage release 110V	56.00
CCUN240V	Under voltage release 240V	56.00
CCUN415V	Under voltage release 415V	56.00
CCAS415V	Shunt release 415V	43.50
CCPV	Emergency stop button	39.50
CCHS11	Auxiliary Contact Block 1NO/1NC Side Mounting	5.20



CCMS

CCGE1

CCPV

CCUN110V



## Two Speed Dual Wound

**Features:**

- Robust Enclosure - Sheet Steel IP55
- Surface Mounting Type: 3DW
- Hand reset thermal overloads
- Three Phase
- Standard Coil Voltages: 50/60Hz
- Built in High/Stop Reset/Low Push Buttons
- Provision for remote control
- Colour RAL7035 Light Grey
- 24V, 48V, 110V, 230V, 400V, 440V and more

Max FLC (415V 3ph)	kW	Approx. (HP)	Without Isolator		With Isolator	
			Reference	List Price £	Reference	List Price £
12	5.5	(7.5)	3DW1---S	240.50	3DW1---I	307.00
18	7.5	(10)	3DW2---S	258.50	3DW2---I	324.50

For Two Speed Dual Wound Starters above 7.5kW - P.O.A. FLC required for high and low speeds



3DW1EFKS

## Two Speed Pole Change

**Features:**

- Robust Enclosure - Sheet Steel IP55
- Surface Mounting Type: 3PC
- Sheet Steel Enclosure
- Hand reset thermal overloads
- Three Phase
- Standard Coil Voltages: 50/60Hz
- Built in High/Stop Reset/Low Push Buttons
- Provision for remote control
- Colour RAL7035 Light Grey
- 24V, 48V, 110V, 230V, 400V, 440V and more

Max FLC (415V 3ph)	kW	Approx. (HP)	Without Isolator		With Isolator	
			Reference	List Price £	Reference	List Price £
12	5.5	(7.5)	3PC1---S	414.00	3PC1---I	500.00
18	7.5	(10)	3PC2---S	431.00	3PC2---I	529.50
25	11	(15)	3PC3---S	468.50	3PC3---I	602.00

Please note: Overload setting range - High Speed Overload first in the code reference and to be rated half the Full Load Current of the motor For Two Speed Pole Change Starters above 11kW - P.O.A. Motor Connection details required

## Single Phase Series Parallel

**Features:**

- Robust Enclosure - Sheet Steel IP55
- Surface Mounting Type: 3SP
- Built in High/Stop Reset/Low Push Buttons
- Single Phase
- Standard Coil Voltages: 50/60Hz
- Hand reset thermal overloads
- Capacitor Start/Capacitor Run or Induction Run
- 100/110V, 220/230V, 480V
- Provision for remote control

Max FLC (240V 1ph)	kW	(HP)	Without Isolator		With Isolator		With Isolator & Mains Fuses	
			Reference	List Price £	Reference	List Price £	Reference	List Price £
24	3.0	(5)	3SP1--S	353.00	3SP1--I	497.00	3SP1--F	557.00
30	5.5	(7.5)	3SP2--S	364.50	3SP2--I	517.00	3SP2--F	606.00

Please note: Overload setting range - Overload rated half Full Load Current of motor, for Single Phase Series Parallel Starters above 5.5kW - P.O.A. For motor frame sizes D160/180 & Electrodrive motors - P.O.A.



3PC1EKLS



3SP1CHS

## Direct-on-Line Duty Standby - Dual Pump & Fan Control

**Features:**

- Robust Enclosure - Sheet Steel IP55
- Surface Mounting Type: 3DS
- Two Motor D-O-L
- Single Phase or Three Phase
- Standard Coil Voltages: 50/60Hz
- Hand reset thermal overloads
- Duty Selector & Reset Push Button
- Colour RAL7035 Light Grey
- 24V, 48V, 110V, 230V, 400V, 440V and more
- Provision for remote control

Max FLC (415V 3ph)	kW	Approx. (HP)	Without Isolator		With Isolator	
			Reference	List Price £	Reference	List Price £
12	5.5	(7.5)	3DS1--S	277.50	3DS1--I	341.50
18	7.5	(10)	3DS2--S	287.50	3DS2--I	353.00

For Duty Stand Starters above 7.5kw - P.O.A.



**Duty Standby Starters** are a dedicated starter for standard Dual Pump Control systems. Operates the manually selected Duty Pump and automatically switches over to the Standby Pump in the event of the Duty Pump tripping out on overload. This is the most basic pump control product available, specially customised or branded products are available incorporating duty assist, timed duty rotation, level switch control, status indication, signalling, soft start/stop, variable speed pressure/flow control, sleep function and advanced pump protection from dry running, blockage and cavitation on request. Please contact us to discuss your specific requirements.



3DS1ELS

# Crompton Enclosures *Empty, Full or Colourful*

Crompton Controls are happy to provide our own, well known boxes to meet all customers requirements, large or small..!

We also stock a wide range of **plastic, GRP, sheet steel, stainless & aluminium enclosures** along with a host of components and accessories ready to build into any preferred specification including contactors, transformers, MCB's, terminal blocks, isolators, push buttons, lamps, switches and any other Control or BMS peripheral...

**We can even provide Crompton Enclosures in Special colours on request!**



BOX SIZE Colour Chart BELOW

## Series 3000 Enclosures

Plain Epoxy finish, colour RAL 7035

Reference	Description	List Price £
3EBS21	Size 1 enclosure DIN Rail fitted accepting CC09/CC12/CC18 or CC25 contactor	30.00
3EBS22	Size 2 enclosure chassis fitted accepting 2 x CC25 Contactors	44.00
3EBS23	Size 3 enclosure chassis fitted accepting component combinations	47.00
3EBS24	Size 4 enclosure chassis fitted accepting component combinations	54.50

IP55 enclosure: Sheet steel

## Isolators in Steel Enclosures

Suitable for motor isolation (AC23) in IP55 enclosures

Reference	Current Rating AC1	Approx. kW at 240V	Height	Dimensions (mm) Width	Depth	List Price £
MI1S	20A	5.5	174	104	134	85.00
MI2S	30A	7.5	174	104	134	95.00
MI3S	60A	18.5	184	184	149	195.00
MI4S	72A	22	184	184	149	215.00



Special Box Colours  
Also Available On  
Request..!

### Series 3000 Enclosure Sizes

SIZE CHART applies to all standard Series 3000 Enclosures

Ref	Pressed Steel Enclosure Dimensions			Fixings 4 x 4.5 Diameter	
	H (mm)	W (mm)	D (mm)	H (mm)	W (mm)
Size 1	174	104	134	130	60
Size 2	184	184	149	140	140
Size 3	184	284	149	140	240
Size 4	305	285	159	260	240

**Note:** Highlighted Enclosures are Crompton Controls pressed steel with removable lids. All others have hinged doors with dimensions available on request.

# What **bits** are **in** your **boxes**..?

You name it we will **custom build** it..!



3ENC4/40N

## Enclosed Single, Triple and Four Pole Contactors for Heating & Lighting load Control - IP55

### Common Features:

- Supplied with 220/240V 50Hz coils as standard.
- All units are designed for two wire control circuit c/w fuse protection suitable for Time Switch, Thermostat, Sensor or other remote controls
- Optional On/Off Switch, Local/Remote Switch, Indicator Lamps and Control Fuses
- Robust sheet steel IP55 enclosures

### Single Pole and Neutral complete with Fuse Protection

Reference	Current Rating AC1	Approx. kW at 240V	Dimensions (mm)			List Price £
			Height	Width	Depth	
3HS1S	60A	14	184	184	149	94.50
3HS3S	100A	24	305	285	159	147.00
3HS5S	180A	43	300	300	210	310.00
3HS6S	275A	66	300	300	210	405.50



3HS1S

### Triple Pole and Neutral complete with Fuse Protection

Reference	Current Rating AC1	Approx. kW at 240V	Dimensions (mm)			List Price £
			Height	Width	Depth	
3HT1S	25A	6.0	184	184	149	77.00
3HT3S	40A	9.0	184	184	149	101.50
3HT5S	72A	17.0	305	285	159	228.00
3HT6S	110A	26.0	305	285	159	369.00
3TEH13	135A	32.4	300	300	210	508.50
3TEH15	150A	36.0	600	400	210	591.50
3TEH18	180A	43.2	600	400	210	632.50
3TEH22	220A	52.8	600	400	210	873.00



3HT3S

Extras (Types 3HS & 3HT only) 2 pole aux' contact block / 4 pole aux' contact block add £10.00 / £16.00

### 4 Pole complete with Neutral Blocks and Oversize Enclosures for ease of wiring

Reference	Current Rating AC1	Approx. kW at 240V	Dimensions (mm)			List Price £
			Height	Width	Depth	
3ENC4/25N	25A	6	184	184	149	89.00
3ENC4/40N	40A	9	184	184	149	126.50
3ENC4/60N	60A	17	305	285	159	253.50
3ENC4/125N	125A	26	305	285	159	376.00





**EASY SPEEDY**



Try our online savings & payback calculator to see how much you could save...

Typical / Approximate Saving  
 10% SLOWER = 25% SAVING  
 20% SLOWER = 45% SAVING  
 30% SLOWER = 65% SAVING



# Energy Efficient Variable Speed Starters



**Motor Control** *in a box packed full of benefits*

Key considerations for installing an Easy Speedy Enclosed Variable Speed Drive with internally mounted speed potentiometer:

- Brand New Range of 0.25kW to 22kW Enclosed Inverter Panels **supplied ready to run**
- Latest Emotron VS Inverters with Integral EMC Filter & Keypad/Display fitted as standard
- Reduced Energy Consumption: **Pre-set** via internally mounted adjustable speed potentiometer
- Reduced **Co2** Emissions helping larger companies hit **Co2** targets & reduce their carbon footprint
- Reduced Inrush Current: **Pre-set** Soft Start Ramp Up Feature
- Reduced Mechanical Wear: Soft Start, Soft Stop & Slower Running Speed
- **Easy** Installation: Just wire in the Mains Supply & Connect the Motor - just like a DOL Starter!
- Improved Protection: Built in Short Circuit, Overload, Voltage Imbalance & Earth Fault detection
- Compact IP54 Enclosures with Ventilation Fans & Filters
- Simple: Start & Stop External Push Buttons

Typical / Approximate Saving  
 10% SLOWER = 25% SAVING  
 20% SLOWER = 45% SAVING  
 30% SLOWER = 65% SAVING

 **Call us NOW for Technical Help and Pricing..!**

# The Easy Speedy Standard Range

The Standard Range of 0.25kW to 22kW enclosed inverter panels are supplied ready to run and fitted as standard with:



- The Latest Emotron FDU & VS Inverters
- Integral EMC Filter & Keypad/Display
- Compact IP54 Enclosures with Ventilation Fans & Filters
- Mains Supply & Motor Connection Terminals
- Simple Start & Stop Push Buttons
- Internally Mounted Energy Saving Potentiometer



**EASY SPEEDY**

SINGLE PHASE 230V MAINS SUPPLY - FOR CONTROLLING 3 PHASE 230VAC MOTORS

REFERENCE	KG	kW	AMPS	H x W x D	LIST PRICE £
CC1P-0.25EVSD	7.5	0.25	1.7@230V	300 x 300 x 200	485.50
CC1P-0.37EVSD	7.5	0.37	2.4@230V	300 x 300 x 200	491.50
CC1P-0.55EVSD	7.5	0.55	3.2@230V	300 x 300 x 200	529.50
CC1P-0.75EVSD	7.5	0.75	4.2@230V	300 x 300 x 200	545.00
CC1P-1.1EVSD	10	1.1	6.0@230V	400 x 300 x 200	595.50
CC1P-1.5EVSD	10	1.5	7.0@230V	400 x 300 x 200	627.00
CC1P-2.2EVSD	10	2.2	9.6@230V	400 x 300 x 200	659.50

THREE PHASE 400V & NEUTRAL MAINS SUPPLY - FOR CONTROLLING 3 PHASE 400VAC MOTORS

REFERENCE	KG	kW	AMPS	H x W x D	LIST PRICE £
CC3P-0.37EVSD	7.5	0.37	1.3@400V	300 x 300 x 200	560.00
CC3P-0.55EVSD	7.5	0.55	1.8@400V	300 x 300 x 200	568.50
CC3P-0.75EVSD	7.5	0.75	2.4@400V	300 x 300 x 200	583.00
CC3P-1.1EVSD	10	1.1	3.2@400V	400 x 300 x 200	660.50
CC3P-1.5EVSD	10	1.5	3.9@400V	400 x 300 x 200	676.50
CC3P-2.2EVSD	10	2.2	5.6@400V	400 x 300 x 200	701.50
CC3P-3EVSD	11	3	7.3@400V	400 x 300 x 200	785.50
CC3P-4EVSD	11	4	9.5@400V	400 x 300 x 200	904.50
CC3P-5.5EVSD	11	5.5	13@400V	400 x 300 x 200	987.50
CC3P-7.5EVSD	16	7.5	16.5@400V	500 x 400 x 200	1,106.00
CC3P-11EVSD	48	11	25@400V	800 x 600 x 300	1,890.50
CC3P-15EVSD	48	15	30@400V	800 x 600 x 300	2,146.50
CC3P-18.5EVSD	48	18.5	36@400V	800 x 600 x 300	2,449.00
CC3P-22EVSD	48	22	45@400V	800 x 600 x 300	2,661.00

Note - all smaller sizes up to 1.1kW have vents, larger sizes also have a fan for heat dissipation

Easy Speedy starts with the above standard specification but can also be **Easily & Speedily Tailored** to suit your specific requirements with Extra or Customised Features including:

- Additional Switchgear & Controls
- Alternative Enclosure Options
- Higher Powers & Motor Drive Packages up to 1400 kW

**MASSIVE ENERGY SAVINGS**

See for yourself with our online Savings & Payback Calculator...

Pre-set the saving & close the door on rising energy costs!

Save up to 65% by slowing down your electric motors...



 BOX SIZE Colour Chart - See Page 23

# Safely **STOP**

## Your Woodworking Machines

& Comply with PUWER98 Regulation 15

- Controlled DC Injection Braking
- START / PROTECT / STOP
- Strong Pressed Steel IP55 Enclosures
- Simple Retro-Fit
- Solutions For All Machines



Machine  
Tools



Rotating  
Wheels



Conveyors



Winders



Mixers

**S10**  
**brake**

### Market Leading S10 Brakes

Crompton Controls have manufactured DC Injection Brakes for over 50 years and are now a recognised market leader. All of our products have been designed and developed in house and provide rapid controlled braking of AC electric motors driving rotating industrial machines. Braking Systems have been provided to thousands of Woodworking Machine suppliers and users for Controlled Safety Stopping in accordance with the requirement of PUWER 98. As a result we have many customised control solutions available.

### Automatic DC Injection Brake Controllers

Start, protect and safely stop standard Rotating Machines

**Features:**

- Controlled stopping for compliance to PUWER 98
- IP55 Dust proof
- Compact surface mounting sheet steel enclosures for easy retrofitting
- Complete with integral Start and Stop Push Buttons
- Simple braking time and torque setting
- Suitable for up to 12 stops per hour

### Direct-on-Line Three Phase

400V / 3ph / 50Hz

Motor FLC	Motor Rating kW	Reference	Module List Price £	Card List Price £	Enclosure Height	Enclosure Width	Enclosure Depth
4-6	2.2	3DCM1EHS	498.00	548.50	184	184	149
5.5-8	3	3DCM1EJS	507.50	558.00	184	184	149
7-10	4	3DCM1EKS	510.50	561.00	184	184	149
10-12	5.5	3DCM1ELS	542.00	595.50	184	184	149
13-18	7.5	3DCM2EMS	611.50	(674.50)	184(305)	184(285)	149(159)
18-25	11	3DC3ENS		687.00	305	285	159
25-32	15	3DC4ECS		777.50	400	400	210
32-40	22	3DC5ESS		1,162.00	400	400	210

Typical applications: Dimension and Circular Saws

In 3DCM, 3DPM & 3DYM "M" denotes S10 Brake Module fitted. For Crosscut saws or similar with increased stopping rates alternative Power & Control Cards are required

### Direct-on-Line Single Phase

230V / 1ph / 50Hz

Motor FLC	Motor Rating kW	Reference	Module List Price £	Card List Price £	Enclosure Height	Enclosure Width	Enclosure Depth
4-6	0.5	3DPM1CHS/10	489.50	541.00	184	184	149
10-12	1.5	3DPM1CLS/10	507.50	557.00	184	184	149
13-18	2.2	3DPM2CMS/10	510.50	(561.00)	184(184)	184(284)	149(149)

Typical applications: Circular Saws and Tennon Machines

### Star Delta Three Phase

400V / 3ph / 50Hz

Motor FLC	Motor Rating kW	Reference	Module List Price £	Card List Price £	Enclosure Height	Enclosure Width	Enclosure Depth
9.5-13.8	5.5	3DYM1EJS	691.00	(759.50)	305(500)	285(400)	159(210)
12-17	7.5	3DYM1EKS	733.00	(807.50)	305(500)	285(400)	159(210)
17-21	11	3DY1ELS		832.00	500	400	210
22-30	15	3DY2EMS		902.00	500	400	210
31-43	22	3DY3ENS		1,388.50	600	600	210
39-55	30	3DY4ECS		2,996.00	700	500	210

Typical applications: Panel and Rip Saws

### DC Injection Modular Kits & Spares

Reference	Part Number	List Price £
S10 Brake Module 400V	BR011	252.50
S10 Brake Module 230V	BR016	252.50
Brake Contactor 400V Coil	CC1201-400V	35.00
Brake Contactor 240V Coil	CC1201-230V	35.00
Control Fuse Holder	FC014	7.50
Control Fuse	FL071	2.15
DB5 Driver Card 400V	BR002	150.00
DB2 Power Card	BR003	150.00
DB2 Control Card 400V	BR004	150.00
Mains Fuse 30A	FL078	5.50

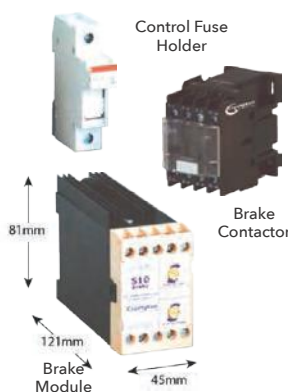

3DCM1ELS



3DCM1EKS  
S10 DC Injection Brake (Module)



3DC3ENS  
S10 DC Injection Brake (Driver Card)



### SIZES: S10 Brake Colour Chart

Ref	Pressed Steel Enclosure Dimensions (mm)			Fixings 4 x 4.5 Diameter (mm)	
	H	W	D	H	W
Size 1	174	104	134	130	60
Size 2	184	184	149	140	140
Size 3	184	284	149	140	240
Size 4	305	285	159	260	240

Note: Highlighted Enclosures are Crompton Controls pressed steel with removable lids. All others have hinged doors with dimensions available on request.

## Advanced Technology Smooth - BRAKES

In addition to Safety Braking, our technology is also widely used to provide Controlled Braking to a wide range of Rotating Industrial Machines to improve production efficiencies by reducing process or tool changeover times in applications such as Grinding & Polishing Machines, Mixers, Conveyors, Centrifuges, Lathes and many other Machine Tools.



### Smooth - BRAKE Control Systems

Smoothest possible braking eliminates shocks, vibration and noise. Developed to be mechanically kind to Band Resaw type machines.

**Features:**

- Unique 3 stage automatic voltage ramp down to zero
- Soft application of high initial DC injection
- Low level final DC stage with surge reduction
- Automatic cut off at zero speed
- Simple adjustment – shut off timer and torque level potentiometers

**Standard Specification:**

Mains Supply: 400V/3ph/50Hz  
 Crompton Controls developed Smooth-BRAKE module  
 Extremely compact IP55 Dustproof enclosures with top & bottom access  
 Star Delta main motor starter with Stop/Start push buttons  
 Direct On Line Feeder motor starter with Stop/Start push buttons  
 Track/Run selector switch – press and hold Start to track  
 110V AC control circuit via integral fused transformer  
 Provision for control from external Stop/Start pushbuttons  
 Braking times up to approx 50 seconds



SmoothBRAKE11

**DC injection Braking** is an approved method of stopping AC electric motors and requires the mains supply to be present to operate correctly.

**Specialist DC Braking...**

## Star Delta Smooth Brake - Control Panels, Assemblies & Modules

400V / 3ph / 50Hz

Maximum Current FLC	Current (DC)	Motor Power kW	Motor Power (HP)	Reference	List Price £	Height	Width	Depth
21	(35)	11	(15)	SmoothBRAKE11	1,172.00	400	300	240
30	(45)	15	(20)	SmoothBRAKE15	1,221.50	400	300	240
90		11/22	(15/30)	BR026 Brake Assembly	529.50	100	160	125
...All Ratings...				BR024 - Spare Control Module only	256.20	74	45	121

**Notes:**

- i) Control panels are pre-engineered and complete with **Standard Specification** above
- ii) Brake Assemblies require additional Contactors and Fusing components for retro-fit into customer control systems in accordance with Crompton Controls ref **LT011**

**Installation & Maintenance Instructions**

- iii) BR024 is a spare Control Module for the current BR026 & previous BR025 Brake Assemblies

## D.C. Injection Brake Units 'SPINGARD'

Including Trip Arm and Reset for Button Emergency Stopping of Spindle Drives

Motor Rating	Reference	List Price £	Motor Rating	Reference	List Price £	Motor Rating	Reference	List Price £
4kW (5.5hp)	3SG1S	830.00	7.5kW (10hp)	3SG2S	1,112.00	11kW (15hp)	3SG3S	1,370.50



## PUWER 98 DC Injection Brakes

### DC Injection Brake Control Panels

Designed to safely stop HEAVY DUTY Woodworking Machines



#### Features:

- Controlled stopping for PUWER 98 compliance
- Heavy duty rated for high inertias & longer stopping times
- Star Delta Main Motor starter, Start/Stop push buttons
- Easy supply and motor cable connections
- Terminals to link in external stop controls
- Main Motor Running contact to link to existing feeder control
- Optional Track/Run selector switch, hold to Track push button
- Optional feeder motor DOL starter with stop & start push buttons
- Standard options and customised solutions available

#### Standard Specification:

Mains Supply:	400V/3ph/50Hz
Control Circuit:	110V AC via integral fused transformer
DC brake supply:	11 - 22kW - Internally powered from incoming mains supply 30 - 37kW - Can be wired as above or separately supplied dependant on the rating of the incoming mains supply cables and the level of DC current required to safely brake
Protection:	Super fast semiconductor fuses for protection of power electronics Thermal overload for protection of main motor
Braking Times:	Up to 35 seconds 11 - 22kW, Up to 1 Minute 30 - 37kW
Braking Voltage:	Up to 160V DC maximum
Duty Cycle:	Suitable for up to 12 stops per hour



RESAW18

**Specialist DC Braking...**

### Star Delta Dust Proof Control Panels - IP55

FLC	(DC)	kW	(HP)	Reference	List Price £	Height	Width	(Optional)	Depth
21	(55)	11	(15)	RESAW 11	1,385.00	600	500	(600)	210
30	(72)	15	(20)	RESAW 15	1,541.50	600	500	(600)	210
35	(87)	18.5	(25)	RESAW 18	1,602.50	600	500	(600)	210
43	(107)	22	(30)	RESAW 22	1,670.00	600	500	(600)	210
55	(137)	30	(40)	RESAW 30	3,249.00	1000	800		300
69	(180)	37	(50)	RESAW 37	3,457.00	1000	800		300

Standard Options	List Price £
a) Track/Run selector switch complete with hold to track push button	87.50
b) Feeder Motor DOL starter up to 5.5kW (11 - 22kW)	156.50
Complete with Stop/Start Push Buttons (30 - 55kW)	180.00
c) Main Motor Thermistor Protection Relay	71.00
d) Main Motor Fuse Protection (11 - 22kW)	102.00
(30 - 37kW)	156.00

 Call us **NOW** for Technical Help and Pricing..!

# NEW ATEX

## Approved Starters and Accessories



- Standard DOL & Star Delta
- Zone 1 & Zone 21 Applications
- EEx d II 2GD IP65 T6 up to 50°C
- Special Custom Solutions on Request
- Hazardous Area Cable Glands Available



 Call us **NOW** for Technical Help and Pricing..!

**SERIES EX**

# ATEX Approved Control Equipment

Suitable for Zone 1 & 21 Applications EEx d II 2GD IP65 T6 up to 50°C

*Crompton Controls provides a solution for all motor starting options ATEX approved control equipment!*

## Direct-on-Line

Surface Mounting Types: DLF

# SERIES EX

Max FLC (415V 3ph)	kW	Approx. (HP)	Without Isolator		With Isolator	
			Reference	List Price £	Reference	List Price £
12	5.5	(7.5)	3DLF1--S	P.O.A.	3DLF1--I	P.O.A.
18	7.5	(10)	3DLF2--S	P.O.A.	3DLF2--I	P.O.A.
25	11	(15)	3DLF3--S	P.O.A.	3DLF3--I	P.O.A.
30	15	(20)	3DLF4--S	P.O.A.	3DLF4--I	P.O.A.
50	26	(35)	3DLF5--S	P.O.A.	3DLF5--I	P.O.A.
65	30	(40)	3DLF6--S	P.O.A.	3DLF6--I	P.O.A.

\*Up to 132kW available on request

## Star Delta

Surface Mounting Types: SDF

Max FLC (415V 3ph)	kW	Approx. (HP)	Without Isolator		With Isolator	
			Reference	List Price £	Reference	List Price £
21	11	(15)	3SDF1--S	P.O.A.	3SDF1--I	P.O.A.
30	15	(20)	3SDF2--S	P.O.A.	3SDF2--I	P.O.A.
43	22	(30)	3SDF3--S	P.O.A.	3SDF3--I	P.O.A.
55	30	(40)	3SDF4--S	P.O.A.	3SDF4--I	P.O.A.

\*Up to 185kW available on request

## Control Stations

Thermoplastic

Type	Reference	Description	List Price £
Emergency Stop	FPPBS1ES	1 x M20 Bottom / 1NO + 1NC	P.O.A.
Stop/Start	FPPBS2SS	1 x M20 Bottom / 1NO + 1NC	P.O.A.
Stop/Start/Lamp	FBPBS3SSL	1 x M20 Bottom / 1NO + 1NC + Lamp	P.O.A.
Isolator Switch	FPI1S	1 x M20 Bottom 4 Pole 16A max Pad-lockable	P.O.A.

### Suitable for:

- II 2G EEx edm IIB T6
- II 2D IP66 T80 Deg C
- A Ex edm IIB/Ex edm IIB
- Class I Zone 1
- Class I, Div.2 Groups A,B,C,D
- Cert: PTB 00 ATEX 1068
- Amb. Temp: -55 to +60 Deg C  
(-20 to +60 Deg C for Zone 21 & 22)
- Custom built equipment available on request.



**ATEX GRP Junction Boxes also available** (contact us for the full range & more details)

Suitable for: IP66/68 EExe Category 2 Zone 1 & 21 & Category 3 Zone 2 & 22 -60 Deg C to +55 Deg C

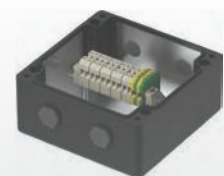

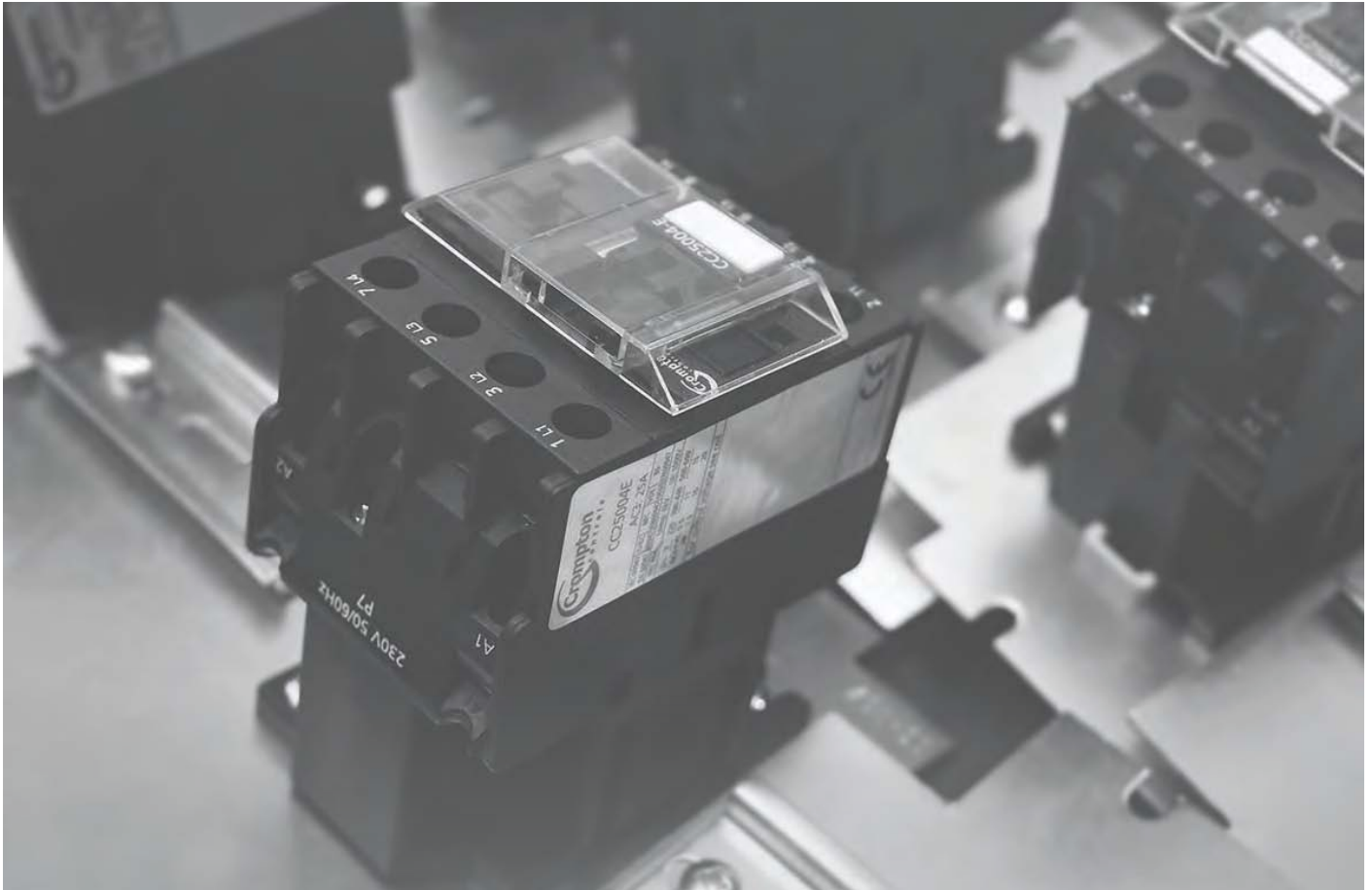

 BOX SIZE Colour Chart - See Page 18

# AC Contactors

## Overloads & Accessories

In Enclosures where required

- Modular Contactors
- Low Height Contactors
- Thermal Overload Relays
- 3 Pole & 4 Pole AC Contactors
- Contactor Accessories, Spares & Sets

 Call us **NOW** for Technical Help and Pricing..!

**RANGE** 

# Modular Contactors

Crompton Controls offer a wide range of Modular Contactors for controlling remote switching and protecting electrical installations. Our Modular Contactors are ideally suited to connecting and breaking non-inductive or low-inductive loads, resistance heaters, household appliances or similar.

## Full Range of Modular Contactors complete with 230VAC Coil

REFERENCE	AMPERAGE	SIZE	CONTACT ARRANGEMENT	PRICE £
CC20A1MC2NO	20A 1	18mm	2 pole 2n/o	25.50
CC20A1MC2NC	20A 1	18mm	2 pole 2n/c	25.50
CC25A1MC2NO	25A 1	18mm	2 pole 2n/o	25.50
CC25A1MC2NC	25A 1	18mm	2 pole 2n/c	25.50
CC25A2MC4NO	25A 2	36mm	4 pole 4n/o	43.50
CC25A2MC2NO2NC	25A 2	36mm	4 pole 2n/o, 2n/c	43.50
CC25A2MC4NC	25A 2	36mm	4 pole 4n/c	43.50
CC40A3MC4NO	40A 3	54mm	4 pole 4n/o	60.00
CC40A3MC2NO2NC	40A 3	54mm	4 pole 2n/o, 2n/c	60.00
CC40A3MC4NC	40A 3	54mm	4 pole 4n/c	60.00
CC63A3MC4NO	63A 3	54mm	4 pole 4n/o	60.00
CC63A3MC2NO2NC	63A 3	54mm	4 pole 2n/o, 2n/c	60.00
CC63A3MC4NC	63A 3	54mm	4 pole 4n/c	60.00



NOTE: DIN rail mounting ENCLOSURES available in all materials and sizes on request.

A one module width space between contactors is recommended for heat dissipation and longer life.

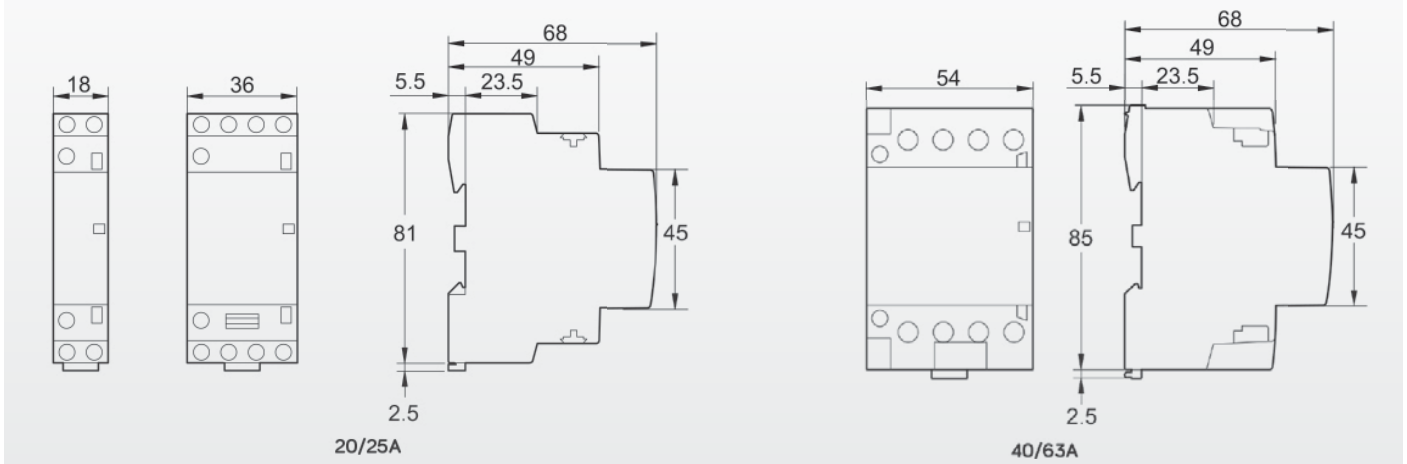

## Low Height Contactors

Up to 25A

### Features:

- Reduced height compared to standard DC contactors
- 3 most common ratings in 2 compact frames sizes
- Price includes Coil
- Requires 75W/3A 24VDC power supply to energise coil



## 3 Pole AC Switching Contactors with 24V DC coils

Reference	AC-3 Rating	AC-1 Rating	Aux Contacts Included	Part Number	List Price £
CCPC09-24	9A	25A	Non Included*	CO509	38.50
CCPC12-24	12A	25A	Non Included*	CO510	41.50
CCPC25-24	25A	40A	Non Included*	CO511	87.00

\*Add On Auxiliary Contact Blocks  
See 3 Pole Contactors & Accessories on page 30  
Other contactors available on request



# RANGE



## AC Contactors & Accessories

up to 105A

### Three Pole AC Contactors

(Price includes coil)

Reference	AC-3 Rating	kW @ 415V	Aux Contacts	AC-1 Rating	List Price £	Reference	AC-3 Rating	kW @ 415V	Aux Contacts	AC-1 Rating	List Price £
CC0910	12A	5.5	1 x N/O	25A	33.50	CC2501	32A	15	1 x N/C	40A	68.00
CC0901	12A	5.5	1 x N/C	25A	33.50	CC3210	40A	18.5	1 x N/O	50A	88.00
CC1210	18A	7.5	1 x N/O	25A	35.00	CC3201	40A	18.5	1 x N/C	50A	88.00
CC1201	18A	7.5	1 x N/C	25A	35.00	CC4011	50A	22	1 x N/O, 1 x N/C	60A	121.00
CC1810	25A	11	1 x N/O	32A	46.00	CC5011	65A	30	1 x N/O, 1 x N/C	80A	157.50
CC1801	25A	11	1 x N/C	32A	46.00	CC6511	80A	37	1 x N/O, 1 x N/C	80A	169.00
CC2510	32A	15	1 x N/O	40A	68.00	CC8011	105A	55	1 x N/O, 1 x N/C	125A	203.50

From Below - Add required AC Voltage & Frequency to Contactor Type to complete the reference, eg, **CC1210-400-50/60**

<b>CC Range AC Coils:</b>	Standard Dual 50/60Hz	Special Dual 50/60Hz	Special 60Hz Only
<b>Voltages Available:</b>	24V, 48V, 110V, 230V, 400V, 440V	120V, 220V, 240V, 380V, 415V, 480V, 500V	208V, 277V, 600V

### Spare Contactor Coils

Reference	Description	List Price £
CX09-18	Fit 09 to 18 Contactors	15.00
CX25-32	Fit 25 to 32 Contactors	19.00
CX40-80	Fit 40 to 80 Contactors	29.50

\*As above - Add the required AC Voltage and Frequency to Contactor and Coil Type



### Mechanical Interlocks

Reference	Description	List Price £
CML09-32	Fit 09 to 32 Contactors	7.50
CML40-65	Fit 40 to 65 Contactors	11.00
CML80	Fit 80 Contactors	11.00



### Add-On Auxiliary Contact Blocks

Front Mounting - N/O Contacts first digit, N/C second digit

Reference	Description	List Price £	Type	Description	List Price £
CBF20	Fit 09 to 80 Contactors	10.00	CBF31	Fit 09 to 80 Contactors	16.00
CBF02	Fit 09 to 80 Contactors	10.00	CBF40	Fit 09 to 80 Contactors	16.00
CBF11	Fit 09 to 80 Contactors	10.00	CBF04	Fit 09 to 80 Contactors	16.00
CBF13	Fit 09 to 80 Contactors	16.00	CBF10	Fit 25 to 65 Contactors	9.00
CBF22	Fit 09 to 80 Contactors	16.00	CBF01	Fit 25 to 65 Contactors	9.00



### Side Mounting - N/O Contacts first digit, N/C second digit

Reference	Description	List Price £	Type	Description	List Price £
CBS20	Fit 09 to 80 Contactors	12.50	CBS11	Fit 09 to 80 Contactors	12.50

### Pneumatic Timer Block - Front Mounting

Reference	Description	List Price £	Type	Description	List Price £
CTD3	3 Sec Delay Off	56.00	CTE3	3 Sec Delay On	56.00
CTD30	30 Sec Delay Off	56.00	CTE30	30 Sec Delay On	56.00
CTD180	180 Sec Delay Off	56.00	CTE180	180 Sec Delay On	56.00

# RANGE

## Thermal Overloads & Accessories

Up to 93A



Manual Overload Reset  
Used in Series 3000 Starters (CR)



Manual/Automatic Reset (CRA)

### Thermal Overload Relays

Manual Reset Type CR

Reference	Amps Range	Description	List Price £	Reference	Amps Range	Type	List Price £
CR09/0.25	0.16 - 0.25	Fit 09 to 32 Contactors	37.00	CR16/18	13 - 18	Fit 09 to 32 Contactors	37.00
CR09/0.4	0.25 - 0.4	Fit 09 to 32 Contactors	37.00	CR25/25	18 - 25	Fit 09 to 32 Contactors	40.50
CR09/0.63	0.4 - 0.63	Fit 09 to 32 Contactors	37.00	CR32/32	23 - 32	Fit 25 to 32 Contactors	68.00
CR09/1	0.63 - 1.0	Fit 09 to 32 Contactors	37.00	CR32/40	28 - 40	Fit 25 to 32 Contactors	68.00
CR09/1.6	1.0 - 1.6	Fit 09 to 32 Contactors	37.00	CR40/32	23 - 32	Fit 40 to 65 Contactors	93.50
CR09/2.5	1.6 - 2.5	Fit 09 to 32 Contactors	37.00	CR40/40	30 - 40	Fit 40 to 65 Contactors	93.50
CR09/4	2.5 - 4.0	Fit 09 to 32 Contactors	37.00	CR63/50	38 - 50	Fit 40 to 65 Contactors	97.50
CR09/6	4.0 - 6.0	Fit 09 to 32 Contactors	37.00	CR63/57	48 - 57	Fit 40 to 65 Contactors	97.50
CR09/8	5.5 - 8.0	Fit 09 to 32 Contactors	37.00	CR63/66	57 - 66	Fit 40 to 65 Contactors	99.50
CR09/10	7.0 - 10.0	Fit 09 to 32 Contactors	37.00	CR80/80	66 - 80	Fit to CC65 Contactor	101.00
CR12/13	10.0 - 13.0	Fit 09 to 32 Contactors	37.00				

Type CMB Mounting Bracket required for use with CC80 Contactor



#### Manual Relay Mounting Brackets Type CMB

Reference	Description	List Price £
CMB09-25	For relays CR09-25	8.50
CMB32	For relays CR32	13.50
CMB40-80	For relays CR40-80	30.50

Start Contacts for Manual Overload Relays only and used in Series 3000 Starters



#### Manual Overload Relay Mounting Start Contacts

Reference	Description	List Price £
CSC09-25B	Fits relays CR09-25	5.00
CSC32B	Fits relays CR32 Only	5.00

### Thermal Overload Relays

Manual/Automatic Reset Type CRA

Reference	Amps Range	Description	List Price £	Reference	Amps Range	Type	List Price £
CRA09/0.25	0.16 - 0.25	Fit 09 to 32 Contactors	44.50	CRA16/18	12 - 18	Fit 09 to 32 Contactors	44.50
CRA09/0.4	0.25 - 0.4	Fit 09 to 32 Contactors	44.50	CRA25/25	18 - 25	Fit 09 to 32 Contactors	48.00
CRA09/0.63	0.4 - 0.63	Fit 09 to 32 Contactors	44.50	CRA32/32	23 - 32	Fit 25 to 32 Contactors	75.50
CRA09/1	0.63 - 1.0	Fit 09 to 32 Contactors	44.50	CRA32/36	28 - 36	Fit 25 to 32 Contactors	75.50
CRA09/1.6	1.0 - 1.6	Fit 09 to 32 Contactors	44.50	CRA40/32	23 - 32	Fit 40 to 95 Contactors	101.00
CRA09/2.5	1.6 - 2.5	Fit 09 to 32 Contactors	44.50	CRA40/40	30 - 40	Fit 40 to 95 Contactors	101.00
CRA09/4	2.5 - 4.0	Fit 09 to 32 Contactors	44.50	CRA63/50	37 - 50	Fit 40 to 95 Contactors	105.00
CRA09/6	4.0 - 6.0	Fit 09 to 32 Contactors	44.50	CRA65/65	48 - 65	Fit 40 to 95 Contactors	105.00
CRA09/8	5.5 - 8.0	Fit 09 to 32 Contactors	44.50	CRA65/70	55 - 77	Fit 40 to 95 Contactors	107.50
CRA09/10	7.0 - 10.0	Fit 09 to 32 Contactors	44.50	CRA80/80	63 - 80	Fit 40 to 95 Contactors	109.00
CRA12/13	9.0 - 13.0	Fit 09 to 32 Contactors	44.50	CRA80/93	80 - 93	Fit 40 to 95 Contactors	118.00

#### Automatic Relay Mounting Brackets Type CMBA

Reference	Description	List Price £
CMBA09-25	For relays CRA09-25	8.50
CMBA32	For relays CRA32	13.50
CMBA40-80	For relays CRA40-80	30.50

#### Four Pole Contactor Style Control Relays

Reference	Description	List Price £
CCR22	2 x N/O & 2 x N/C	35.00
CCR31	3 x N/O & 1 x N/C	35.00
CCR40	4 x N/O Only	35.00



\* Add required AC voltage and Frequency to Relay Type  
CBF/CBS Type Contactor Auxiliary Contact Blocks  
and CX Type Contactor Coils can be fitted

# RANGE

## 3-Pole AC Contactors, Overloads & Accessories

**Features:**

- Common family of 3 & 4-pole versions
- Simple & robust construction
- High mechanical & electrical life
- Full range of add on accessories

### Three Pole AC Contactors

115 to 780A (Price includes Coil)

Reference	AC Rating (A)		Recommended Enclosure Size			List Price £
	AC-1	AC-3	Height	Width	Diameter	
CCF115A	200	115	400	400	210	419.00
CCF150A	250	150	400	400	210	450.50
CCF185A	275	185	400	400	210	568.50
CCF225A	315	225	400	400	210	601.00
CCF265A	350	265	600	400	300	809.00
CCF330A	400	330	600	400	300	1,034.50
CCF400A	500	400	600	400	300	1,226.50
CCF500A	700	500	600	400	300	1,997.50
CCF630A	1000	630	600	400	300	2,536.00
CCF780A	1600	780	600	400	300	5,332.50

\* Other coil voltages available on request

2 x Normally Open & 2 x Normally Closed Auxilliary Contacts Included

\*If shrouds are being fitted check enclosure size



CCF150A

### Thermal Overload Relays

65 to 800A Man/Auto Reset Type CRF - Stand Alone Type

Reference	Amps Range	List Price £
CRF105	65-105	168.50
CRF125	80-125	171.50
CRF160	100-160	177.00
CRF200	125-200	206.50
CRF250	160-250	221.00
CRF315	200-315	232.50
CRF400	250-400	253.50
CRF500	315-500	285.00
CRF630	400-630	320.00
CRF800	500-800	359.50



CRF105

## Accessories for 3 & 4-Pole Contactors

### Protective Shrouds for Contactor Terminals

3-Pole Reference	Set of 6 Shrouds for Contactor	List Price £	4-Pole Reference	Set of 8 Shrouds for Contactor	List Price £
CA9-F701	CCF115A	29.00	CA9-F706	CCF1154A	36.50
CA9-F702	CCF150-CCF185	32.00	CA9-F707	CCF150-1854A	43.50
CA9-F703	CCF225-CCF500A	40.00	CA9-F708	CCF225-CCF5004A	51.00
CA9-F704	CCF630-780A	75.00	CA9-F709	CCF6304A	94.00

### AC Contactor Coils

Reference	For Contactor	List Price £
CCFFE-xx	115-150	37.00
CCFGE-xx	185-225	39.00
CCFH2E-xx	265-330	91.50
CCFJE-xx	400	158.00
CCFKE-xx	500	163.50
CCFCE-xx	630	202.50
CCFE-xxx	780	282.50

### DC Contactor Coils (Special Order In)

Reference	For Contactor	List Price £
CCC4FE-xx	115-150	52.00
CC4FGE-xx	185-225	60.50
CC4FH2E-xx	265-330	105.50
CC4FJE-xx	400	182.00
CC4FKE-xx	500	188.00
CC4FCE-xx	630	232.50
CC4FE-xxx	780	320.50

Replace "xx" below with required voltage i.e. 24, 48, 110, 230, 400, 440V





# RANGE

## 4-Pole AC Contactors, Accessories & Built Up Sets

### 4 Pole Contactors

& Accessories

### Four Pole AC Contactors

(Price includes Coil)

**Features:**

- Fully rated 4th pole
- Simple & robust construction
- High mechanical & electrical life
- Full range of add on accessories
- Interlocked pair under one part number available on request



CCF25004

CCF1504A

Reference	AC Rating (A)		Recommended Enclosure Size			List Price £
	AC-1	AC-3	Height	Width	Depth	
CCF09004	25	9	174	104	134	41.00
CCF12004	25	12	174	104	134	46.50
CCF25004	40	25	184	184	149	72.50
CCF40004	60	40	305	285	159	140.50
CCF50004	80	50	305	285	159	156.00
CCF65004	80	65	305	285	159	186.50
CCF80004	125	80	305	285	159	264.00
CCF95004	125	95	305	285	159	293.00
CCF1154A	200	115	400	400	210	455.00
CCF1504A	250	150	400	400	210	488.50
CCF1854A	275	185	400	400	210	612.50
CCF2254A	315	225	400	400	210	623.00
CCF2654A	350	265	600	400	300	888.50
CCF3304A	400	330	600	400	300	1,112.00
CCF4004A	500	400	600	400	300	1,318.00
CCF5004A	700	500	600	400	300	2,149.50
CCF6304A	1000	630	600	400	300	2,723.00

Other coil voltages available on request

CF1154A and above 2 x Normally Open & 2 Normally Closed Auxilliary Contacts included

\*If shrouds are being fitted check enclosure size

### Mechanical Interlocks

Complete with Rail - Larger sizes also require Base Plates

Reference	For Contactors	List Price £
CML09-32	CC09 to CC25	7.50
CML40-65	CC40 to CC65	11.00
CML80	CC80 to CC95	11.00
CML-FF970	CCF115 to CCF150	25.00
CML-FG970	CCF185 to CC225	37.50
CML-FJ970	CCF265 to CCF500	50.00
CML-FL970	CCF630	75.00



CML40-65

\*Add On Auxiliary Contact Blocks

See 3 Pole Contactors & Accessories on page 32

### Base Plates

For CCF115 to CCF630

Reference	For Contactors	List Price £
CCF115 & CCF150	MI020	81.50
CCF185 & CCF225	MI021	81.50
CCF2654A	MI022	81.50
CCF3304A	MI023	81.50
CCF4004A	MI024	81.50
CCF5004A	MI025	81.50
CCF6304A	MI026	81.50

### Contactor Sets (ideal for Generator changeover)

Either choose your contactors and accessories from above for self-assembly, or contact our internal Technical team now for pre-assembled contactor sets.

**Contactor Set Features:**

- IP55 enclosure to suit set size if required
- 2 x 4-Pole Contactors
- 230V 50/60Hz Coils Standard
- 2 x CBF11 Contact Blocks (CCF09-95 only)
- 1 x Mechanical Interlock & rail
- 1 x Mounting Base plate if required



### SIZES: Enclosure - Colour Chart

Ref	Pressed Steel Enclosure Dimensions			Fixings 4 x 4.5 Diameter	
	H (mm)	W (mm)	D (mm)	H (mm)	W (mm)
Size 1	174	104	134	130	60
Size 2	184	184	149	140	140
Size 3	184	284	149	140	240
Size 4	305	285	159	260	240

**Note:** Highlighted Enclosures are Crompton Controls pressed steel with removable lids. All others have hinged doors with dimensions available on request.

On request **Crompton Controls** offer a full variety of solutions for multiple switching requirements. This includes enclosed Automatic Transfer Panels (ATS), and bypass switch options.



# Panel Mount Components

## Control Stations & Timers

All the basics covered in one place..!

- **Push Buttons & Selector Switches**
- **One Piece LED Pilot Lights**
- **Push Button Control Stations**
- **Standard & Multifunction Digital Timers**
- **Voltage Relays & Protection Units**

 Call us **NOW** for Technical Help and Pricing..!

## 22.5mm Control & Signaling Devices

Comprehensive range of Push Buttons, Indicators Lamps, Key & Selector Switches **IP65 Chrome Bezels** suitable for panel door and enclosed control station mounting.  
**Available as individual items for flexible stocking & assembly**

### Features:

- Each Push Button & Switch requires a Coupler & Contact Block/s
- New LED Lamps are one piece including Lens & Bulb

## Push Buttons

Reference	Description	List Price £
PB013S	Push Button Green Chrome Collar	£5.50
PB017S	Push Button Protruding Red Chrome Collar	£6.00
PB018S	Push Button Flush Red Chrome Collar	£5.50
PB019S	Push Button Red Mushroom Head	£9.00
PB020S	Push Button Red Latching Mushroom Head - Pull to Release	£14.50
PB021S	Push Button Double (Vertical) with Legend (IP40 only)	£10.00
PB048S	Push Button Red Latching Mushroom Head (Key Release)	£21.00
PB054S	Push Button Black Chrome Collar	£5.50
PB055S	Push Button Blue Chrome Collar	£5.50
PB088S	Push Button Red Emergency Stop - Twist to Release	£12.00
PB089S	Push Button Green Chrome Collar with Legend (I)	£7.00
PB090S	Push Button Red Protruding Chrome Collar with Legend (O)	£7.50

Order Coupler & Contact Block Separately

## Illuminated Push Buttons

Reference	Description	List Price £
PB077S	Illuminated Push Button head - Green	£6.00
PB078S	Illuminated Push Button head - Red	£6.00
PB104S	230-130V 1.2W Resistor Lamp Holder supplied with 130V Bulb	£9.00
PB103S	130V 1.2W Lamp Holder (Bulb not included) (Choose from below)	£7.50
BU004	BA9S 24V Bulb	£3.00
BU010	BA9S 60V Bulb	£3.50
BU009	BA9S 130V Bulb	£4.00

Both PB104S and PB103S are complete with coupler. (Contact Blocks to be ordered separately).  
 See below PB039S (N/O) and PB040S (N/C) for contact blocks.

## Key Operated Switches

Referencer	Description	Key Removal Position	List Price £
PB028S	2 Position Switch Non Latching (1x90 deg)	Left	£16.50
PB029S	3 Position Switch Non Latching (2x45 deg)	Centre	£16.50
PB030S	2 Position Switch Latching (1x90 deg)	Left & Right	£15.50
PB031S	2 Position Switch Latching (1x90 deg)	Left	£15.50
PB032S	3 Position Switch Latching (2x45 deg)	Centre	£15.50

Order Coupler & Contact Block Separately

Spare Keys: £4.60 each (DO021C)

To suit above switches only

## Selector Switches

Reference	Description	List Price £
PB033S	2 Position Selector Switch Non Latching (1x90 deg) Spring Return	£7.00
PB034S	3 Position Selector Switch Non Latching (2x45 deg) Spring Return	£7.00
PB035S	3 Position Selector Switch Latching (2x45 deg) Stay Put	£7.00
PB036S	2 Position Selector Switch Latching (1x90 deg) Stay Put	£7.00

Order Coupler & Contact Block Separately

## Contact Blocks

Reference	Description	List Price £
PB039S	N/O Contact Green	£5.00
PB040S	N/C Contact Red	£5.00

Late Break/Early Make contacts available on request.

## Coupler - Required for ALL buttons and Switches

Reference	Description	List Price £
PB093S	Coupler	£1.00



Start Button + Coupler + 1 x NO Contact  
**PB013C + PB093C + PB039C**



3-Way Key Switch + Coupler + 1 x NO Contact  
 + 2 x NC Contacts  
**PB032C + PB093C + PB039C + 2 x PB040C**



2 Way Selector Switch + Coupler + 1 x NO Contact  
**PB035C + PB093C + PB039C**

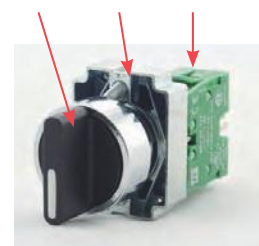

### One Piece LED Pilot Lights - 24V

Reference	Description	Colour	List Price £
PB120S	Lamp LED 24V PL22-24R	RED	9.50
PB121S	Lamp LED 24V PL22-24G	GREEN	9.50
PB122S	Lamp LED 24V PL22-24Y	YELLOW	9.50
PB123S	Lamp LED 24V PL22-24B	BLUE	9.50
PB124S	Lamp LED 24V PL22-24W	WHITE	9.50



### One Piece LED Pilot Lights - 110V

Reference	Description	Colour	List Price £
PB127S	Lamp LED 110V PL22-110R	RED	9.50
PB126S	Lamp LED 110V PL22-110G	GREEN	9.50
PB128S	Lamp LED 110V PL22-110Y	YELLOW	9.50
PB131S	Lamp LED 110V PL22-110B	BLUE	9.50
PB125S	Lamp LED 110V PL22-110W	WHITE	9.50



### One Piece LED Pilot Lights - 230V

Reference	Description	Colour	List Price £
PB107S	Lamp LED 230V PL22-230R	RED	9.50
PB106S	Lamp LED 230V PL22-230G	GREEN	9.50
PB108S	Lamp LED 230V PL22-230Y	YELLOW	9.50
PB109S	Lamp LED 230V PL22-230B	BLUE	9.50
PB110S	Lamp LED 230V PL22-230W	WHITE	9.50



### Push Button Stations

#### Empty Push Button Stations - IP65 Plastic

Part Number	Description	List Price £
PB050C	Push button station 1 hole plastic	£19.00
PB051C	Push button station 2 hole plastic	£21.50
PB052C	Push button station 3 hole plastic	£31.50
PB053C	Push button station 4 hole plastic	£35.50
PB046S	Emergency stop station - 1 unit yellow lid	£17.50
PB049S	Yellow emergency stop plate	£3.70
NP007	Legend plates - blank	£2.00
NP007xx	Legend plates - engraved*	£4.90

Notes: \*Max 24 characters, price for 1-10 plates. 11 plates+ P.O.A.

#### Pre-Assembled Push Button Stations - IP65 Plastic

Part Number	Description	List Price £
PBS1 START	Start	32.00
PBS1 STOP	Stop	33.00
PBS1 STOPM	Mushroom Stop	40.00
PBS1 ES	Emergency Stop	34.00
PBS2 SS	Stop/Start	50.50
PBS2 SSM	Start/Mushroom Stop	64.00
PBS2 UD	Up/Down	50.00
PBS3 FSR	Forward/Stop/Reverse	77.00
PBS3 SSI	Start/Stop/Inch	77.00
PBS3 FMSR	Forward/Mushroom Stop/Reverse	83.00
PBS3 SMSI	Start/Mushroom Stop/Inch	83.00
PBS3 SSP	Start/Stop/Potentiometer	112.00



#### Emergency Stop Button Protective Shrouds (Retro Fit)

Reference	Description	List Price £
PB151	Emergency Stop Shroud - Open Frame	£9.50
PB152	Emergency Stop Shroud - Lift Up Cover	£14.50

## Push Button Stations

### Empty Push Button Stations - IP55 Mild Steel

Reference	Description	List Price £
PB050S	Push button station 1 hole mild steel	£73.00
PB051S	Push button station 2 hole mild steel	£93.00
PB052S	Push button station 3 hole mild steel	£132.50



### Pre-Assembled Push Button Stations - IP55 Mild Steel

Reference	Description	List Price £
PBS1 START/MS	Start	£75.50
PBS1 STOP/MS	Stop	£76.00
PBS1 STOPM/MS	Mushroom Stop	£81.50
PBS1 ES/MS	Emergency Stop	£84.50
PBS2 SS/MS	Stop/Start	£101.50
PBS2 SSM/MS	Start/Mushroom Stop	£107.50
PBS2 UD/MS	Up/Down	£98.00
PBS3 FSR/MS	Forward/Stop/Reverse	£141.00
PBS3 SSI/MS	Start/Stop/Inch	£141.00
PBS3 FMSR/MS	Forward/Mushroom Stop/Reverse	£146.50
PBS3 SMSI/MS	Start/Mushroom Stop/Inch	£146.50
PBS3 USD/MS	Up/Stop/Down	£141.00



### Empty Push Button Stations - IP55 Stainless Steel

Part Number	Description	List Price £
PB050SS	Push button station 1 hole stainless steel	£86.00
PB051SS	Push button station 2 hole stainless steel	£106.00
PB052SS	Push button station 3 hole stainless steel	£145.50



### Pre-Assembled Push Button Stations - IP55 Stainless Steel

Part Number	Description	List Price £
PBS1 START/SS	Start	£89.00
PBS1 STOP/SS	Stop	£89.50
PBS1 STOPM/SS	Mushroom Stop	£95.50
PBS1 ES/SS	Emergency Stop	£98.50
PBS2 SS/SS	Stop/Start	£114.50
PBS2 SSM/SS	Start/Mushroom Stop	£120.50
PBS2 UD/SS	Up/Down	£111.50
PBS3 FSR/SS	Forward/Stop/Reverse	£154.00
PBS3 SSI/SS	Start/Stop/Inch	£152.50
PBS3 FMSR/SS	Forward/Mushroom Stop/Reverse	£158.50
PBS3 SMSI/SS	Start/Mushroom Stop/Inch	£158.50



 Call us **NOW** for Technical Help and Pricing..!



## TIME 2 SWITCH

### Digital Timers & Voltage Relays

#### DIGITAL TIME SWITCH

- Accurate 24 Hour 7 Day Programming
- LCD Display for Easy Set up
- Simple Manual Override Function
- DIN Rail Mounting 90H x 18W x 55D (mm)
- 230V 50/60Hz AC Supply
- Single 16A Resistive 2A Inductive Volt Free Contact

Reference: **CCD24-7PTS 230VAC**  
List Price: **£40.00**



#### MULTI-FUNCTION TIMER RELAY

- 10 Popular Function Settings Selectable
- 8 Adjustable Time Ranges from 0.1 sec to 10 days
- Relay ON or OFF Override Function
- DIN Rail or Screw Mounting 90H x 18W x 64D (mm)
- 12V to 230V 50/60Hz AC/DC Supply with Power On LED
- 16A Resistive 2A Inductive Changeover Contact with Status LED

Reference: **CCMFMTS 12-230VAC/DC**  
List Price: **£45.00**



#### VOLTAGE RELAY 3-PHASE

- 3 or 4 Wire Phase Failure & Phase Sequence Function
- Control & Switching of Voltage & Phase Sensitive Equipment
- 220V to 460V 45/65Hz Phase to Phase Measurement
- DIN Rail or Screw Mounting 90H x 18W x 64D (mm)
- 10A Resistive 1A Inductive Changeover Contact
- Power On & Relay Status LED's

Reference: **CC3WPFSR 220-460VAC**    Reference: **CC4WPFSR 127-264VAC**  
List Price: **£59.50**    List Price: **£63.00**



#### VOLTAGE RELAY 3-PHASE & NEUTRAL

- 4 Wire Phase Failure & Phase Sequence Function
- Selectable Over/Under Voltage Levels + Trip Time
- 127V to 460V 45/65Hz Phase to Neutral Measurement
- DIN Rail or Screw Mounting 90H x 18W x 64D (mm)
- 10A Resistive 1A Inductive Changeover Contact
- Power On & Relay Status LEDs

Reference: **CC4WPFSR127-264VAC04**  
List Price: **£69.00**



### NEW Point of Sale Display also available.

- Compact Slat Wall Cover
- Complete with hooks
- Clam packed components
- Timers & Voltage Relays included
- Modular Contactors included
- Contact us for more details



## Special Application Timers & Protection Units for special starter & motor applications.

- Fan Shaker Timer
- Star Delta Timer
- Multi-Voltage Standard Timer
- Thermistor Protection Relay
- Complete starters available!



Example shows Fan Shaker Starter c/w timer fitted

### FAN SHAKER Timer for Dust Extraction Systems

Fan Shaker Timer	Type FS2. Voltages: 110V, 220/240V, 380/440V	List Price £
<b>FUNCTION</b>	Dedicated timer for main fan and shaker Motor Control	
	<ul style="list-style-type: none"> <li>• 0-120 seconds Fan Run Down time</li> <li>• 0-60 seconds Shake/Clean period</li> <li>• 110V, 230V 400V options available</li> </ul>	
<b>REFERENCES</b>	FS2 110V, FS2 230V, FS2 400V	
		£121.00

### STAR DELTA Timer for Star Delta motor starting

Star Delta Timer	Type YD. Voltages: 110V, 220/240V, 380/440V	List Price £
<b>FUNCTION</b>	Double relay timer for Star Delta starting.	
	<ul style="list-style-type: none"> <li>• Multi-Voltage 110V, 230V &amp; 400V standard, 24V option</li> <li>• 75 millisecond Star to Delta delay</li> <li>• 30 second (YD30S), 1 min (YD1M) (YDL1M) &amp; 2 min (YD2M) versions</li> </ul>	
<b>REFERENCES</b>	YD30S, YD1M, YD2M / YDL1M	
		£82.50 / £126.50

### STANDARD Timer for Delay on Energisation up to 400V

Standard Timer	Type TM. Voltages: 110V, 220/240V, 380/440V	List Price £
<b>FUNCTION</b>	Delay on energisation	
	<ul style="list-style-type: none"> <li>• Multi-Voltage 110V, 230V &amp; 400V standard, 24V option</li> <li>• On power up, relay operates after set delay period</li> <li>• 7 time delay versions available - 30 second (TM30S), 1 min (TM1M), etc.</li> </ul>	
<b>REFERENCES</b>	TM30S, TM1M, TM2M, TM4M, TM8M, TM16M, TM20M	
		£68.50

### THERMISTOR PROTECTION Relay for Motor Protection

Thermistor Protection Unit	Type TH. Voltages: 110/230V, 230/440V	List Price £
<b>FUNCTION</b>	Protection against over-temperature damage to motor windings.	
	<ul style="list-style-type: none"> <li>• Prevents overtemperature damage to industrial motors</li> <li>• For use with PTC motor embedded Thermistors</li> <li>• 24V (TH24) 110V/230V (TH110) &amp; 230/400V (TH415) options</li> </ul>	
<b>REFERENCES</b>	TH24, TH110, TH415	
		£68.50



**DID YOU KNOW** Crompton Controls & Emotron have partnered for over 2 decades..?



# EMOTRON

## Power & Industrial Solutions

Great partner range available including:

- **Shaft Power Monitors**
- **Electronic Soft Starters**
- **Variable Speed Drives**
- **Rotary Heat Exchanger Equipment**
- **Drive & Motor Packages**

 Call us **NOW** for Technical Help and Pricing..!



## Shaft Power Monitors

### Proactive High Specification Measurement

For Machine and Process Protection



#### Features:

- Prevents dry running, cavitation and jamming in pumps
- For rated motor currents up to 999A
- Uses the motor as a sensor through a matched current transformer
- Automatic setting of alarm levels
- Modular DIN rail mounting for simple installation
- IP20 Protection class
- Typical applications include Pumps, Mixers, Agitators, Blenders, Scrapers, Conveyors, Machine tools, Automatic Gates and Doors



Model EL - FI	Supply Voltage	Inputs	Outputs	Reference	Approximate Dimensions (mm)			List Price £
					Height	Width	Depth	
<b>M20</b>	1ph 100-240V	Up to 999 Amps	2 x N/O Relay	<b>SS070</b>	90	45	115	<b>496.00</b>
	3ph 100-240V	Auto Set & Reset	Alarm & Pre-alarm 1 x Analogue					
<b>M20</b>	3ph 380-500V	Up to 999 Amps	2 x N/O Relay	<b>SS074</b>	90	45	115	<b>496.00</b>
		Auto Set & Reset	Alarm & Pre-alarm 1 x Analogue					

#### Please Note:

- The above prices include the relevant Current Transformer for up to 100A
- Please specify the motor FLC or which CT is required as shown in the spares options below
- Above 100 Amps FLC an additional CT is required - P.O.A.
- For 525-690V supply/motor voltages - P.O.A.

## EL - FI Shaft Power Monitor Options

Options	Description	Reference	List Price £
<b>FPK1</b>	Front panel mounting kit including terminal covers spare Current Transformers	<b>SS076</b>	<b>91.00</b>
<b>CTM10</b>	0.4 to 10.0A FLC	<b>SS071</b>	<b>35.00</b>
<b>CTM25</b>	10.1 to 25.0A FLC	<b>SS073</b>	<b>35.00</b>
<b>CTM50</b>	26.0 to 50.0A FLC	<b>SS072</b>	<b>35.00</b>
<b>CTM100</b>	51.0 to 100.0A FLC	<b>SS075</b>	<b>70.00</b>
<b>Terminal Covers</b>	2 off	<b>SS080</b>	<b>6.00</b>



#### NEW for OLD!

Please note the above EL-FI M20 Shaft Power Monitors now replace previous models as follows: EL-FI models LM, DLM, G3, V3, V5, V6, PM & FM.

Please quote the old model voltage input, Part & Serial Numbers when enquiring

# Emotron M20

## Reliable and cost-efficient monitoring

 Call us **NOW** for Technical Help and Pricing..!

**TSA Soft Starters**  
**with built-in bypass & Shaft Power Monitor**  
*Everything you need except variable speed!*



A Brand New Level of Soft Starter Motor Control

**Features:**

- Integrated By-pass with proven contactor technology
- Soft torque starting, intelligent monitoring, smart stops
- Simple, robust & compact construction
- Coated printed circuit boards for harsh environments
- Slow speed, jog and reverse with no extra hardware
- Built in realtime clock
- Clear multilingual text display
- Option 575 - 670V AC version on request



70 - 100A

**TSA Soft Starters**

Three Phase 200 - 525V AC 50/60Hz - IP20 Modules

TSA Model	Normal Duty* A	Normal Duty kW @400V	Height (mm)	Width (mm)	Depth (mm)	Reference	List Price £
TSA-016	16	7.5	246	126	188	SS084	P.O.A.
TSA-022	22	11	246	126	188	SS085	P.O.A.
TSA-030	30	15	246	126	188	SS086	P.O.A.
TSA-036	36	18.5	246	126	188	SS087	P.O.A.
TSA-042	42	22	246	126	188	SS088	P.O.A.
TSA-056	56	30	246	126	188	SS089	P.O.A.
TSA-070	70	37	246	126	188	SS090	P.O.A.
TSA-085	85	45	246	126	188	SS091	P.O.A.
TSA-100	100	55	246	126	188	SS092	P.O.A.
TSA-140	140	75	285	196	235	SS093	P.O.A.
TSA-170	170	90	285	196	235	SS094	P.O.A.
TSA-200	200	110	285	196	235	SS095	P.O.A.
TSA-240	240	132	373	254	260	SS096	P.O.A.
TSA-300	300	160	373	254	260	SS097	P.O.A.
TSA-360	360	200	373	254	260	SS098	P.O.A.
TSA-450	450	250	373	254	260	SS099	P.O.A.



140 - 200A

\*Note: Normal duty - Start Amps=3xInom, Start Time=15sec to 56A & 30sec to 100A @ 10 Starts/Hour

**TSA Soft Starter Options**

Option	Reference	List Price £
IP54 External Control Panel for cabinet door mounting	SS102	P.O.A.
I/O Board with 3 extra relay outputs & 3 extra digital inputs	SS103	P.O.A.
PTC & PT100 input board	SS104	P.O.A.
RS485 serial communications board - Modbus-RTU protocol	SS105	P.O.A.
Profibus DP V1 fieldbus option	SS106	P.O.A.
Devicenet fieldbus option	SS107	P.O.A.
Industrial Ethernet Profinet IO (RT) 1	SS108	P.O.A.
Industrial Ethernet Profinet IO (RT) 2 port	SS100	P.O.A.
Industrial Ethernet with Modbus/TCP protocol	SS101	P.O.A.
Industrial Ethernet EtherCAT (COE)	SS109	P.O.A.
Industrial Etherne/IP, 2 Port	SS110	P.O.A.
Industrial USB Serial Communications Board - Modbus-RTU protocol	SS111	P.O.A.



240 - 450A

Call us **NOW** for Technical Help and Pricing..!

## MSF Soft Starters with Braking & Shaft Power Monitor

### Features:

- Simplified Setting, New Functionality and More Flexible I/O
- Menu format coordinated with the new Emotron FDU and VFX drives
- New Front Panel - Emotron family look and improved keypad design
- High Specification features built in as standard for more applications and reduced cost
- Reduces water hammer
- Protects pumps from damage
- Special pump control feature

- Standard 200-525V AC Supply/Motor Voltage
- Option 690V AC Supply/Motor Voltage on request
- 100-240V or 380-500V AC Control Voltage options

### MSF Soft Starters

IP20 (NEMA 1) Up to MSF835 / IP (NEMA 0) MSF1000 & 1400



Model MSF	Approximate Dimensions (mm)					110 - 240V Control Reference	380 - 500V Control Reference	List Price £
	A	kW*	Height	Width	Depth			
MSF17	17	7.5	320	126	260	SS051	SS051A	P.O.A.
MSF30	30	15	320	126	260	SS052	SS052A	P.O.A.
MSF45	45	22	320	126	260	SS053	SS053A	P.O.A.
MSF60	60	30	320	126	260	SS054	SS054A	P.O.A.
MSF75	75	37	320	126	260	SS055	SS055A	P.O.A.
MSF85	85	45	320	126	260	SS056	SS056A	P.O.A.
MSF110	110	55	400	176	260	SS057	SS057A	P.O.A.
MSF145	145	75	400	176	260	SS058	SS058A	P.O.A.
MSF170	170	90	500	260	260	SS059	SS059A	P.O.A.
MSF210	210	110	500	260	260	SS060	SS060A	P.O.A.
MSF250	250	132	500	260	260	SS061	SS061A	P.O.A.
MSF310	310	160	532	547	278	SS062	SS062A	P.O.A.
MSF370	370	200	532	547	278	SS063	SS063A	P.O.A.
MSF450	450	250	532	547	278	SS064	SS064A	P.O.A.
MSF570	570	315	687	640	302	SS065	SS065A	P.O.A.
MSF710	710	400	687	640	302	SS066	SS066A	P.O.A.
MSF835	835	450	687	640	302	SS067	SS067A	P.O.A.
MSF1000	1000	560	900	875	336	SS068	SS068A	P.O.A.
MSF1400	1400	800	900	875	336	SS069	SS069A	P.O.A.

\*Approximate kW @ 400V 3ph AC supply/motor voltage

### MSF Soft Starter Options

Description	Reference	List Price £
Cable kit for external mounting CT's in bypass	XG825	P.O.A.
Factory fitted remote keypad mounting kit	XG826	P.O.A.
Retrofit fitted remote keypad mounting kit	XG994	P.O.A.
Cable entry box (MSF17 - 85 only)	XH002	P.O.A.

### Please note:

- Complete control panels on request
- For up to 690V supply/motor voltage price on application

### Communication Software Options

Options	List Price £
RS238 / RS485	P.O.A.
PROFIBUS DP	P.O.A.
DEVICENET	P.O.A.

### Diagnostic Capability:

- 3ph Current
- 3ph Voltage
- Power kW
- Energy consumption kWh
- Elapsed time

### Standards:

EMC Emissions: EN50081-2 with by pass  
EMC Immunity: EN50082-2

### General Electrical Data:

Voltage Tolerances: Control Voltage  $\pm 10\%$   
Motor Voltage 200 - 525  $\pm 10\%$

### Recommended fuse

for Control Card: 10 Amp max

Frequency: 50/60Hz  $\pm 10\%$

Relay Outputs: 3 x 8 Amp, 250 AC

Operating Temp: 0 to 40°C + 10°C derate by 20% power reduction

Protection Degree: IP20 <90kW, IP20 >90kW

Overload: Torque control 700% boost for 2 seconds, 250% during Ramp  
Voltage control 250% during Ramp

 Call us **NOW** for Technical Help and Pricing..!

## EMOTRON VS10, VS30 (IP20) Inverters - As fitted inside Easy Speedy (page 20) Smooth & Efficient Operation

Emotron VS10 and VS30 offers reliable and cost-efficient operation of your pumps, fans and compressors as well as constant torque applications such as conveyors. All are supplied complete with built-in EMC filter as standard. The complete series covers motors in the power range of 0.25 - 7.5 kW.

Although small in size, our new Emotron VS10 and VS30 drive is equipped with several advanced features. It offers great flexibility in all senses. Functionality is easily adapted to your specific application requirements. The compact format offers flexible installation and the user-friendly set-up will have your system up and running in no time.

**Features:**

1. Key hole mounting
2. Main Power Supply removable connector
3. Motor Power Terminal removable connector
4. Relay output
5. Memory module
6. CAN connection with shield plate fixation (option)
7. HMI interface: Control panel hot-pluggable (keypad included)
8. I/O Terminal with shield plate



### VS10 (IP20) 1-phase supply: 230V Input - 0 to 230V 3 Phase Output

Model VS	Nominal Power		Rated Output Current (A) @ 230V	Approximate Dimensions (mm)			List Price £
	kW	HP		Height	Width	Depth	
VS10-23-1P7-20	0.25	0.33	1.7	155	60	130	P.O.A.
VS10-23-2P4-20	0.37	0.5	2.4	155	60	130	P.O.A.
VS10-23-3P2-20	0.55	0.75	3.2	180	60	130	P.O.A.
VS10-23-4P2-20	0.75	1.0	4.2	180	60	130	P.O.A.
VS10-23-6P0-20	1.1	1.5	6.0	250	60	130	P.O.A.
VS10-23-7P0-20	1.5	2.0	7.0	250	60	130	P.O.A.
VS10-23-9P6-20	2.2	3.0	9.6	250	60	130	P.O.A.

### VS30-23 (IP20) 1/3 - phase supply: 230V Input - 0 to 230V 3 Phase Output

Model VS	Nominal Power		Rated Output Current (A) @ 230V	Approximate Dimensions (mm)			List Price £
	kW	HP		Height	Width	Depth	
VS30-23-1P7-20	0.25	0.33	1.7	155	60	130	P.O.A.
VS30-23-2P4-20	0.37	0.5	2.4	155	60	130	P.O.A.
VS30-23-3P2-20	0.55	0.75	3.2	180	60	130	P.O.A.
VS30-23-4P2-20	0.75	1.0	4.2	180	60	130	P.O.A.
VS30-23-6P0-20	1.1	1.5	6.0	250	60	130	P.O.A.
VS30-23-7P0-20	1.5	2.0	7.0	250	60	130	P.O.A.
VS30-23-9P6-20	2.2	3.0	9.6	250	60	130	P.O.A.

### VS30-40 (IP20) 3 - phase supply: 400V Input - 0 to 400V 3 Phase Output

Model VS	Nominal Power		Rated Output Current (A) @ 400/480V	Approximate Dimensions (mm)			List Price £
	kW	HP		Height	Width	Depth	
VS30-40-1P3-20	0.37	0.5	1.3 / 1.1	155	60	130	P.O.A.
VS30-40-1P8-20	0.55	0.75	1.8 / 1.6	180	60	130	P.O.A.
VS30-40-2P4-20	0.75	1.0	2.4 / 2.1	180	60	130	P.O.A.
VS30-40-3P2-20	1.1	1.5	3.2 / 3.0	250	60	130	P.O.A.
VS30-40-3P9-20	1.5	2.0	3.9 / 3.5	250	60	130	P.O.A.
VS30-40-5P6-20	2.2	3.0	5.6 / 4.8	250	60	130	P.O.A.
VS30-40-7P3-20	3.0	4.0	7.3 / 6.3	250	90	130	P.O.A.
VS30-40-9P5-20	4.0	5.0	9.5 / 8.2	250	90	130	P.O.A.
VS30-40-013-20	5.5	7.5	13 / 11	275	120	130	P.O.A.
VS30-40-016-20	7.5	10.0	16.5 / 14	275	120	130	P.O.A.

Call us **NOW** for Technical Help and Pricing..!

## VS10 & VS30 General Specifications

Mains voltage	VS10: 1-phase, 190-240V +/-10% VS30-23: 1/3 phase, 190-240V +/-10% VS30-40: 3 phase, 380-480V +/-10%
Mains frequency	45Hz...65Hz
Output voltage	3-phase, 0-Mains supply voltage level
Output frequency	0-599 Hz
Degree of Protection	IP20 / NEMA250
Mounting	Zero clearance side by side upright mounting, without derating
Cooling	Direct Air cooling (>= Unit size 3 with fan)
Connections	Spring loaded control terminals Removable power terminals <=2.2kW
Approvals	CE, UL, cUL, RoHS2
EMC compliance	IEC 61800-3:2004 - C1/C2 depending on length of motor cable
Overload capacity	200% rated current for 3s 150% rated current for 60s
Switching frequency	2,4,8,16 kHz
Temperature	-10°C - 55°C /4kHz (>45°C/ reduce rated output current by 2.5 %/°C)

## Standard Functions and Features

Control types, motor control	VVFC control plus (linear or square-law V/Hz) Sensor less vector control (speed) Fixed / Auto-Boost DC Brake / Brake control Flying restart
Basic functions	Freely assignable user menu S-shaped ramps for smooth acceleration PID controller Sequencer Parameter set change-over Sleep / rinse function
Monitoring and protective measures	Short circuit Earth fault I <sup>2</sup> x t monitoring Motor phase failure Mains phase failure Motor over temperature/heat sink (de-rating) Motor maximum speed detection Motor maximum torque detection Motor maximum current detection Load loss monitoring
Diagnostics Diagnostic interface	Error management via LED, Failure history, Log (Control panel)



## Options

Available Options	
CAN Open	Communication bus
Modbus-RTU	RS485 Serial communication
USB	Communication module



PUMPS

FANS

COMPRESSORS

HVAC

# MASSIVE ENERGY SAVINGS

See for yourself with our online Savings & Payback Calculator...

Save up to 65% by slowing down your electric motors...

Pre-set the saving & close the door on rising energy costs!

## EMOTRON FDU 2.0 Inverter Drive - IP20/IP54

The Emotron FDU 2.0 AC drive is a step forward from the VS range and has added features. It is specially developed for controlling variable torque loads such as flow and pressure applications. It continuously adapts motor speed to the level required, minimising energy consumption and wear.

A unique monitoring functionality protects your process from damage and unplanned downtime. Typical applications are pumps, fans, compressors and blowers.

### Features:

- Robust and certified IP20 or IP54 metal construction as standard offers cost-efficient installation close to the application.
- All drive sizes are delivered with built-in Category C3 EMC-filter as standard. C3 requirements are fulfilled with 80m motor cable.
- Soft starts minimise start currents and linear stops prevent water hammer.
- One Emotron FDU can control up to seven pumps/fans without external control systems.
- Energy saving function pauses the motor when it is not required to run to maintain pressure.
- Efficiency is increased by setting the pump to run at full speed at certain intervals to rinse out sludge.
- Speed controlled fans assures less noise, a more even drive temperature and higher efficiency.
- Module fuses included as standard for sizes above 300A at 480V and above 250A at 690V.
- Detachable multi-language control panel included as standard.  
Following languages are supported in the control panel:  
English, Swedish, Dutch, German, French, Spanish, Russian, Italian, Czech, and Turkish.
- Operation parameters can be set in your process units, for example m<sup>3</sup>/min. and bar.
- Removable control panel with own memory means it is easy to transfer or copy settings.
- UL (UL 840) and marine (DNV/BV) approved standard drive.
- Liquid cooled version available for sizes above 90A.



### FDU 2.0 - 2Y (IP20) 3-phase Supply Un = 380, 400, 415, 440, 460, 480V +10%/-15%, IP20 with brake\*\*

Frame Size A3, B3, C3 (No AC or DC Choke included)

Reference	Normal Duty 120%			Heavy Duty 150%			Imax (60s) A*	Approximate Dimensions (mm)			List Price £
	(400V) kW	(460V) HP	A	(400V) kW	(460V) HP	A		Height	Width	Depth	
FDU48- 2P5-2Y	0.75	1.0	2.5	0.55	0.75	2.0	3.0	245	120	169	P.O.A.
FDU48- 3P4-2Y	1.1	1.5	3.4	0.75	1.0	2.7	4.1	245	120	169	P.O.A.
FDU48- 4P1-2Y	1.5	2.0	4.1	1.1	1.5	3.3	4.9	245	120	169	P.O.A.
FDU48- 5P6-2Y	2.2	3.0	5.6	1.5	2.0	4.5	6.7	245	120	169	P.O.A.
FDU48- 7P2-2Y	3.0	4.0	7.0	2.2	3.0	5.8	8.6	245	120	169	P.O.A.
FDU48- 9P5-2Y	4.0	5.0	9.5	3.0	4.0	7.6	11.4	245	120	169	P.O.A.
FDU48- 12-2Y	5.5	7.5	12.0	4.0	5.0	9.6	14.4	245	120	169	P.O.A.
FDU48- 16-2Y	7.5	10.0	16.0	5.5	7.5	12.8	19.2	285	145	179	P.O.A.
FDU48- 23-2Y	11.0	15.0	23.0	7.5	10.0	18.4	27.6	285	145	179	P.O.A.
FDU48- 32-2Y	15.0	20.0	31.0	11.0	15.0	24.8	37.2	365	190	187	P.O.A.

\*Available for a limited time and as long as drive temperature permits. Rated data at 40°C ambient temperature.

\*\* If you order the Brake Chopper option, it is mounted internally in the drive. The brake resistors are not included and need to be ordered separately. Please contact us for add on options, selection and pricing.

### FDU 2.0 (IP20) 3-phase Supply Un = 380, 400, 415, 440, 460, 480V +10%/-15%, IP20/21 optional brake\*\*

Frame Size C2, D2, E2, F2 (DC Choke included)

Reference	Normal Duty 120%			Heavy Duty 150%			Imax (60s) A*	Approximate Dimensions (mm)			List Price £
	(400V) kW	(460V) HP	A	(400V) kW	(460V) HP	A		Height	Width	Depth	
FDU48- 025-20	11.0	15.0	25.0	7.5	10.0	20.0	30.0	438	176	267	P.O.A.
FDU48- 030-20	15.0	20.0	30.0	11.0	15.0	24.0	36.0	438	176	267	P.O.A.
FDU48- 036-20	18.5	25.0	36.0	15.0	20.0	29.0	43.0	438	176	267	P.O.A.
FDU48- 045-20	22.0	30.0	45.0	18.5	25.0	36.0	54.0	438	176	267	P.O.A.
FDU48- 058-20	30.0	40.0	58.0	22.0	30.0	46.0	68.0	438	176	267	P.O.A.
FDU48- 072-20	37.0	50.0	72.0	30.0	40.0	58.0	86.0	545	220	291	P.O.A.
FDU48- 088-20	45.0	60.0	88.0	37.0	50.0	70.0	106.0	545	220	291	P.O.A.
FDU48- 105-20	55.0	75.0	105.0	45.0	60.0	84.0	126.0	545	220	291	P.O.A.
FDU48- 142-20	75.0	100.0	142.0	55.0	75.0	114.0	170.0	956	275	294	P.O.A.
FDU48- 171-20	90.0	125.0	171.0	75.0	100.0	137.0	205.0	956	275	294	P.O.A.
FDU48- 205-20	110.0	150.0	205.0	90.0	125.0	164.0	246.0	956	335	294	P.O.A.
FDU48- 244-20	132.0	200.0	244.0	110.0	150.0	195.0	293.0	956	335	294	P.O.A.

\*Available for a limited time and as long as drive temperature permits. Rated data at 40°C ambient temperature.

\*\* If you order the Brake Chopper option, it is mounted internally in the drive. The brake resistors are not included and need to be ordered separately. Please contact us for add on options, selection and pricing.

## EMOTRON FDU 2.0 Inverter Drive - IP20/IP54



**FDU 2.0, 3-phase Supply Un = 380, 400, 415, 440, 460, 480V +10%/-15%, IP54/20 optional brake\*\***  
 Frame Size B, C, D, E, F & G-O (DC Choke included)

Reference	IP Rating	Normal Duty 120%			Heavy Duty 150%			Imax (60s) A*	Approximate Dimensions (mm)			List Price £
		(400V) kW	(460V) HP	A	(400V) kW	(460V) HP	A		Height	Width	Depth	
FDU48-003-54	IP54	0.75	1.0	2.5	0.55	1.0	2.0	3.0	350	203	200	P.O.A.
FDU48-004-54	IP54	1.5	2.0	4.0	1.1	1.5	3.2	4.8	350	203	200	P.O.A.
FDU48-006-54	IP54	2.2	3.0	6.0	1.5	2.0	4.8	7.2	350	203	200	P.O.A.
FDU48-008-54	IP54	3.0	3.0	7.5	2.2	3.0	6.0	9.0	350	203	200	P.O.A.
FDU48-010-54	IP54	4.0	5.0	9.5	3.0	3.0	7.6	11.4	350	203	200	P.O.A.
FDU48-013-54	IP54	5.5	7.5	13.0	4.0	5.0	10.4	15.6	350	203	200	P.O.A.
FDU48-018-54	IP54	7.5	10.0	18.0	5.5	7.5	14.4	21.6	350	203	200	P.O.A.
FDU48-026-54	IP54	11.0	15.0	26.0	7.5	10.0	21.0	31.0	440	178	292	P.O.A.
FDU48-031-54	IP54	15.0	20.0	31.0	11.0	15.0	25.0	37.0	440	178	292	P.O.A.
FDU48-037-54	IP54	18.5	25.0	37.0	15.0	20.0	29.6	44.0	440	178	292	P.O.A.
FDU48-046-54	IP54	22.0	30.0	46.0	18.5	25.0	37.0	55.0	440	178	292	P.O.A.
FDU48-061-54	IP54	30.0	40.0	61.0	22.0	30.0	49.0	73.0	545	220	295	P.O.A.
FDU48-074-54	IP54	37.0	50.0	74.0	30.0	40.0	59.0	89.0	545	220	295	P.O.A.
FDU48-090-54	IP54	45.0	60.0	90.0	37.0	50.0	72.0	108.0	950	285	314	P.O.A.
FDU48-109-54	IP54	55.0	75.0	109.0	45.0	60.0	87.0	131.0	950	285	314	P.O.A.
FDU48-146-54	IP54	75.0	100.0	146.0	55.0	75.0	117.0	175.0	950	285	314	P.O.A.
FDU48-175-54	IP54	90.0	125.0	175.0	75.0	100.0	140.0	210.0	950	285	314	P.O.A.
FDU48-210-54	IP54	110.0	150.0	210.0	90.0	125.0	168.0	252.0	950	345	314	P.O.A.
FDU48-250-54	IP54	132.0	200.0	250.0	110.0	150.0	200.0	300.0	950	345	314	P.O.A.
FDU48-300-20	IP20	160.0	250.0	300.0	132.0	200.0	240.0	360.0	1036	500	390	P.O.A.
FDU48-375-20	IP20	200.0	300.0	375.0	160.0	250.0	300.0	450.0	1036	500	390	P.O.A.
FDU48-430-20	IP20	220.0	350.0	430.0	200.0	250.0	344.0	516.0	1036	500	450	P.O.A.
FDU48-500-20	IP20	250.0	400.0	500.0	220.0	350.0	400.0	600.0	1036	500	450	P.O.A.
FDU48-600-20	IP20	315.0	500.0	600.0	250.0	400.0	480.0	720.0	1036	730	450	P.O.A.
FDU48-650-20	IP20	355.0	550.0	650.0	315.0	400.0	520.0	780.0	1036	730	450	P.O.A.
FDU48-750-20	IP20	400.0	600.0	750.0	355.0	500.0	600.0	900.0	1036	730	450	P.O.A.
FDU48-860-20	IP20	450.0	700.0	860.0	400.0	550.0	688.0	1032.0	1036	1100	450	P.O.A.
FDU48-1K0-20	IP20	560.0	800.0	1000.0	450.0	650.0	800.0	1200.0	1036	1100	450	P.O.A.
FDU48-1K15-20	IP20	630.0	900.0	1150.0	500.0	750.0	920.0	1380.0	1036	1365	450	P.O.A.
FDU48-1K25-20	IP20	710.0	1000.0	1250.0	560.0	800.0	1000.0	1500.0	1036	1365	450	P.O.A.
FDU48-1K35-20	IP20	710.0	1100.0	1350.0	600.0	900.0	1080.0	1620.0	1036	1630	450	P.O.A.
FDU48-1K5-20	IP20	800.0	1250.0	1500.0	630.0	1000.0	1200.0	1800.0	1036	1630	450	P.O.A.
FDU48-1K75-20	IP20	900.0	1500.0	1750.0	800.0	1200.0	1400.0	2100.0	1036	2000	450	P.O.A.
FDU48-2K0-20	IP20	1120.0	1700.0	2000.0	900.0	1300.0	1600.0	2400.0	1036	2230	450	P.O.A.
FDU48-2K25-20	IP20	1250.0	1900.0	2250.0	1000.0	1500.0	1800.0	2700.0	1036	2530	450	P.O.A.
FDU48-2K5-20	IP20	1400.0	2100.0	2500.0	1120.0	1700.0	2000.0	3000.0	1036	2830	450	P.O.A.

\*Available for a limited time and as long as drive temperature permits. Rated data at 40°C ambient temperature.

\*\* If you order the Brake Chopper option, it is mounted internally in the drive. The brake resistors are not included and need to be ordered separately. Please contact us for add on options, selection and pricing.

Call us **NOW** for Technical Help and Pricing..!



## EMOTRON VFX 2.0 Inverter Drive - IP20/IP54

The Emotron VFX 2.0 AC drive is the complete package and optimises your process and prevents damage and downtime.

The combination of direct torque control, accurate speed control, and efficient vector braking makes it the ideal solution for all dynamic and constant torque applications, such as: cranes, crushers, mills, mixers and centrifuges.



### Features:

- Robust and certified IP20 or IP54 metal construction as standard offers cost-efficient installation close to the application.
- All drive sizes are delivered with built-in Category C3 EMC-filter as standard. C3 requirements are fulfilled with 80m motor cable.
- Direct torque control reacts extremely quickly and eliminates disturbances due to abrupt load changes
- Soft starts minimise start currents and full motor overload capacity is available from standstill.
- UL (UL 840) and marine (DNV/BV) approved version available.
- Integrated vector braking ensures quick and controlled stops, increasing productivity and safety.
- Built in brake chopper option.
- Speed controlled fans assures less noise, a more even drive temperature and higher drive efficiency.
- Module fuses included as standard for sizes above 300A at 480V and above 250A at 690V.
- Detachable multi-language control panel included as standard.  
Following languages are supported in the control panel:  
English, Swedish, Dutch, German, French, Spanish, Russian, Italian, Czech, and Turkish.
- Operation parameters can be set in your process units, for example m/sec, tons/h or cycles/min.
- Removable control panel with own memory means it is easy to transfer or copy settings.
- Liquid cooled version available for sizes above 90A.



### VFX 2.0 - 2Y, (IP20) 3-phase Supply Un = 380, 400, 415, 440, 460, 480V +10%/-15%, IP20 with brake\*\*

Frame Size A3, B3, C3 (No AC or DC Choke included)

Reference	Normal Duty 120%			Heavy Duty 150%			Imax A*	Approximate Dimensions (mm)			List Price £
	(400V) kW	(460V) HP	A	(400V) kW	(460V) HP	A		Height	Width	Depth	
VFX48- 2P5-2Y	0.75	1.0	2.5	0.55	0.75	2.0	3.8	245	120	169	P.O.A.
VFX48- 3P4-2Y	1.1	1.5	3.4	0.75	1.0	2.5	5.1	245	120	169	P.O.A.
VFX48- 4P1-2Y	1.5	2.0	4.1	1.1	1.5	3.0	6.2	245	120	169	P.O.A.
VFX48- 5P6-2Y	2.2	3.0	5.6	1.5	2.0	3.8	8.4	245	120	169	P.O.A.
VFX48- 7P2-2Y	3.0	4.0	7.2	2.2	3.0	5.5	10.8	245	120	169	P.O.A.
VFX48- 9P5-2Y	4.0	5.0	9.5	3.0	4.0	6.8	14.3	245	120	169	P.O.A.
VFX48- 12-2Y	5.5	7.5	12.0	4.0	5.0	9.0	18.0	245	120	169	P.O.A.
VFX48- 16-2Y	7.5	10.0	16.0	5.5	7.5	12.0	24.0	280	145	179	P.O.A.
VFX48- 23-2Y	11.0	15.0	23.0	7.5	10.0	17.0	34.5	280	145	179	P.O.A.
VFX48- 32-2Y	15.0	20.0	31.0	11.0	15.0	24.0	46.5	365	190	187	P.O.A.

\*Available for a limited time and as long as drive temperature permits. Rated data at 40°C ambient temperature.

\*\* Brake Chopper - Dynamic Braking Transistor internal option (optional DB Resistor not included)

Please contact us for add on options, selection and pricing.

### VFX 2.0, (IP20) 3-phase Supply Un = 380, 400, 415, 440, 460, 480V +10%/-15%, IP20/21 optional brake\*\*

Frame Size C2, D2, E2, F2 (DC Choke included)

Reference	Normal Duty 120%			Heavy Duty 150%			Imax A*	Approximate Dimensions (mm)			List Price £
	(400V) kW	(460V) HP	A	(400V) kW	(460V) HP	A		Height	Width	Depth	
VFX48- 025-20	11.0	15.0	25.0	7.5	10.0	20.0	38.0	438	176	267	P.O.A.
VFX48- 030-20	15.0	20.0	30.0	11.0	15.0	24.0	45.0	438	176	267	P.O.A.
VFX48- 036-20	18.5	25.0	36.0	15.0	20.0	29.0	54.0	438	176	267	P.O.A.
VFX48- 045-20	22.0	30.0	45.0	18.5	25.0	36.0	68.0	438	176	267	P.O.A.
VFX48- 060-20	30.0	40.0	60.0	22.0	30.0	48.0	90.0	545	220	291	P.O.A.
VFX48- 072-20	37.0	50.0	72.0	30.0	40.0	58.0	108.0	545	220	291	P.O.A.
VFX48- 088-20	45.0	60.0	88.0	37.0	50.0	70.0	132.0	545	220	291	P.O.A.
VFX48- 106-20	55.0	75.0	106.0	45.0	60.0	85.0	127.0	956	275	294	P.O.A.
VFX48- 142-20	75.0	100.0	142.0	55.0	75.0	114.0	170.0	956	275	294	P.O.A.
VFX48- 171-20	90.0	125.0	171.0	75.0	100.0	137.0	205.0	956	275	294	P.O.A.
VFX48- 205-20	110.0	150.0	205.0	90.0	125.0	164.0	246.0	956	335	294	P.O.A.
VFX48- 244-20	132.0	200.0	244.0	110.0	150.0	195.0	293.0	956	335	294	P.O.A.

\*Available for a limited time and as long as drive temperature permits. Rated data at 40°C ambient temperature.

\*\* Brake Chopper - Dynamic Braking Transistor internal option (optional DB Resistor not included)

Please contact us for add on options, selection and pricing.



**Options FDU-VFX, IP2Y**  
Frame Size A3, B3, C3

Option	Reference	After Mounted	List Price £ Coated
Profibus	01-6070-05	Fieldbus option Profibus DP V1*	P.O.A.
Devicenet	01-6070-06	Fieldbus option DeviceNet*	P.O.A.
ProfiNet, 1 port	01-6070-11	Industrial Ethernet option Profinet IO (RT), 1 port*	P.O.A.
ProfiNet, 2 port	01-6070-12	Industrial Ethernet option Profinet IO (RT), 2 port*	P.O.A.
Modbus/TCP	01-6070-09	Industrial Ethernet option with Modbus/TCP protocol*	P.O.A.
EtherCat	01-6070-10	Industrial Ethernet option EtherCAT (CoE)*	P.O.A.
EtherNet-IP, 2 port	01-6070-13	Industrial Ethernet IP, 2 port*	P.O.A.
PTC micro	01-6070-08	1 PTC input confirming DIN 44081/44082	P.O.A.
Safe stop micro	01-6070-02	Extra build-in inputs and outputs for emergency stop circuit confirming with the norm EN 954-1 Category 3.	P.O.A.
RS 232/485 micro	01-6070-07	Isolated RS232/485 serial communication board,	P.O.A.

\*Available aslo for FDU/VFX IP20/54

Option	Factory mounted	List Price £
DC+/DC-Connectors	Frame size B	P.O.A.
	Frame size C, C2	P.O.A.
	Frame size D, D2	P.O.A.
	Frame size E, E2	P.O.A.
	Frame size F, F2	P.O.A.
IT-Net	The variable speed drive will be factory-made for using IT-Net.	P.O.A.
Standby power supply	Build-in standby power supply, suitable for 24V AC/DC. If the main power supply drops out, the control print and the connected options, for example Profibus, will stay commissioned.	P.O.A.
Safe Stop	Extra build-in inputs and outputs for emergency stop circuit confirming with the norm EN 954-1 Category 3.	P.O.A.
Control panel blank	Factory mounted when ordering an external control panel	P.O.A.
PTC frame sizes B - D, C2 & D2	Factory mounted, isolated motor PTC input conform DIN 44081/440 82 for sizes B - D, C2 & D2	
EMC filter	EMC filter according to class C2 - 1st enviroiment, restricted distribution.	
	Frame size B	P.O.A.
	Frame size C, C2	P.O.A.
	Frame size D, D2(60, 72A) Frame size D2 (88A)	P.O.A.

Set by of the VSD configuration (see page Conf\_INV)

Call us **NOW** for Technical Help and Pricing..!



**DID YOU KNOW**

**DID YOU KNOW**

Crompton Controls offer the complete Variable Speed Drive Solution, from Single Drives, through to specially designed Multi-Drive Panels..!

## EMOTRON EMX-R Drive System for Rotary Heat Exchangers

The EMX-R drive system is a range of speed controlled drive systems for rotary heat exchangers. A system consists of a motor and a corresponding electronic controller.

Uniquely, EMX-R is equipped with an integrated electronic rotation sensor, RotoSens™, which eliminates the need for a mechanical sensor.

The system can also easily handle a conventional mechanical rotation sensor if so desired. The EMX-R drive systems are based on the switched reluctance (SR) motor technology. The SR technology allows the EMX-R motor to drive heat exchanger wheels with diameters up to 3.5 m without any need for a gearbox. The result is fewer mechanical wear parts and therefore a lower Life Cycle Cost (LCC), also the efficiency is substantially increased while all gear losses are eliminated.

The motor can run in both directions and has a permanently attached motor cable for easier installation.

To further support an easy installation, no adjustments and settings are required to get the drive system into operation. For maximum performance and efficiency in a rotary heat exchanger, low speed as well as high speed is required. The EMX-R system therefore offers full control over a wide speed range. To prevent involuntary heat transference, holding torque is activated in the motor to hold a rotor still. The drive system learns which rotor requires holding torque.

The EMX-R drive is available in three different sizes; 15, 25 and 35. The following table illustrates the maximum wheel diameters in decimeter with a maximum wheel speed of 10 to 12 rpm. The controller is available in two versions; S (Standard functionality) and E (Extended functionality). Model E has an extra circuit board for increased functionality.

*Contact us for further information...*



**Efficient & Reliable..!**

### Features:

- Robust motor without gear or fan.
- Integrated electronic rotation sensor eliminates the need for mechanical sensors.
- High efficiency - No gearbox losses.
- A wide speed range for maximum usage of the high efficiency in the exchanger wheel.
- Easy handling since no adjustments or settings are required.
- Selectable direction of rotation.
- Integrated motor cable.
- Extensive protection against short circuit, overloading etc.
- Holding torque – prevents involuntary heat transference



### Motors

Reference	Model		List Price £
01-2160-00	EMX-R-15M		P.O.A.
01-2162-00	EMX-R-25M		P.O.A.
01-2163-00	EMX-R-35M		P.O.A.
01-5071-00	EMX-D Motor+gearbox 10 3:1	axle length 40mm	P.O.A.
01-5071-10	EMX-D Motor+gearbox 10 3:1	axle length 60mm	P.O.A.
01-5072-00	EMX-D Motor+gearbox 15 5:1	axle length 40mm special	P.O.A.

### Control Units

Reference	Model	List Price £
01-2170-11	EMX-R-15S Emotron	P.O.A.
01-2171-11	EMX-R-15E Emotron	P.O.A.
01-2174-11	EMX-R-25S Emotron	P.O.A.
01-2175-11	EMX-R-25E Emotron	P.O.A.
01-2176-11	EMX-R-35S Emotron	P.O.A.
01-2177-11	EMX-R-35E Emotron	P.O.A.
01-3090-00	EMX-P10	P.O.A.
01-5070-00	EMX-D Control unit	P.O.A.

### Equipment for EMX-R-15-35

Reference	Model	List Price £
01-3660-00	Cable gland kit for control unit for EMX-R-15-35	P.O.A.
01-2182-00	Mounting kit, type Expander for motor EMX-R-15-35	P.O.A.
01-2183-00	Mounting kit, 2xM6 for motor EMX-R-15-35	P.O.A.
01-2184-00	Rotation sensor with magnet for EMX-R-15-35	P.O.A.

**Note:** EMX-P & EMX-D controllers & Drive Systems also available on request..!

## TECHNICAL NOTE



### Replacement of Older Drive System to EMX-R

When replacing older drive system EMS-VVX for rotary heat exchanger to EMX-R, both the motor and control unit must be replaced. Below is a table of drive systems replacing the expired drive systems EMS-VVX 1, 2 and 4. When replacing EMS-VVX 15-35 with EMX-R, it is not necessary to replace both motor and control unit.

Motors can be replaced with the same size. When replacing control units, make sure the EMX-R control unit is set for "Rotation monitor ON" (DIP 4).

If the system shall run without both external and internal rotation monitor, (rotation monitor with sensor or built-in electronic rotation monitor RotoSens) set DIP 4 in "OFF-position" and put a link between terminal 31 and 32, see also the manual.

Expired Old Drive System	Rotor Diameter	Expired Drive System - July 05	Replaced by Drive System
EMS-VVX 1/ET	<1500mm	EMS-VVX 15S	EMX-R-15S
EMS-VVX 2FR EMS-VVX 2FR/ET EMS-VVX 2N/STD EMS-VVX 2N/ET	<1500mm >1500mm	EMS-VVX 15S EMS-VVX 25S	EMX-R-15S EMX-R-25S
EMS-VVX 2EM	<1500mm >1500mm	EMS-VVX 15E EMS-VVX 25E	EMX-R-15E EMX-R-25E
EMS-VVX 4R EMS-VVX 4R/ET EMS-VVX 4N/STD EMS-VVX 4N/ET	<2500mm >2500mm	EMS-VVX 25S EMS-VVX 35S	EMX-R-25S EMX-R-35S
EMS-VVX 4EM	<2500mm >2500mm	EMS-VVX 25E EMS-VVX 35E	EMX-R-25E EMX-R-35E

#### Check List

- Most often a pulley with different diameter is required to achieve the correct maximum speed.
- When a V-belt is used it may be advisable to replace even the motor support bracket to achieve the correct belt tension.

#### Example of Replacement Kit

The parts in a replacement kit can be motor, control unit, pulley and motor support bracket.

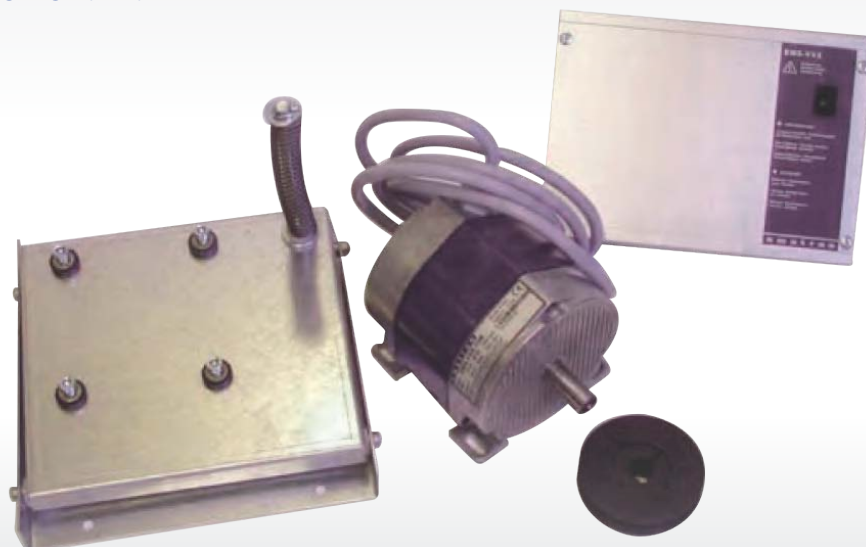

 Call us **NOW** for Technical Help and Pricing..!

# YASKAWA Variable Speed Drives

**DID YOU KNOW** Crompton Controls & Yaskawa have partnered for more than 10 years?

New State of the art GA500 & GA700 added to well-known J1000, V1000 & A1000 ranges



## GA500 Microdrive - IP20



Balancing Power to Perfection - Makes Life Easier!  
Compact & flexible for almost all industrial applications.

### Features:

- Dual Rated Constant & Variable Torque
- Bright LED display & tactile keypad
- Side by side mounting reduces panel size
- Mobile or PC connectivity via USB port
- One drive for any induction, PM or SR motor
- Supports major communications networks
- Increased functional safety & reliability

### GA500 Inverter Overview

- o 0.1 - 30kW Power Ratings (ND)
- o 200VAC 1ph & 400VAC 3ph
- o Fast Installation & Setup
- o Wide Ambient Temperature Range
- o Braking Transistor built in
- o EMC filter built in as standard
- o Coated PCB's



## Yaskawa GA500 Inverter - Single Phase 200 – 240V AC 50/60Hz – C1 EMC Filter Built in

Inverter Module	Normal Duty		Heavy Duty		Part No.	List Price £
	Amp	kW	Amp	kW		
GA50CB001EBA	1.2	0.18	0.8	0.1	YNE310	P.O.A.
GA50CB002EBA	1.9	0.37	1.6	0.25	YNE311	P.O.A.
GA50CB004EBA	3.5	0.75	3.0	0.55	YNE312	P.O.A.
GA50CB006EBA	6.0	1.1	5.0	1.1	YNE313	P.O.A.
GA50CB0010EBA	9.6	2.2	8.0	1.5	YNE314	P.O.A.
GA50CB0012EBA	12.2	3.0	11	2.2	YNE315	P.O.A.



## Yaskawa GA500 Inverter - Three Phase 380 – 480V AC 50/60Hz – C2 EMC Filter Built in

Inverter Module	Normal Duty		Heavy Duty		Part No.	List Price £
	Amp	kW	Amp	kW		
GA50C4002EBA	2.1	0.75	1.8	0.55	YNE298	P.O.A.
GA50C4004EBA	4.1	1.5	3.4	0.75	YNE299	P.O.A.
GA50C4005EBA	5.4	2.2	4.8	1.5	YNE300	P.O.A.
GA50C4007EBA	7.1	3.0	5.5	2.2	YNE301	P.O.A.
GA50C4009EBA	8.9	4.0	7.2	3.0	YNE302	P.O.A.
GA50C40012EBA	11.9	5.5	9.2	3.7	YNE303	P.O.A.
GA50C40018EBA	17.5	7.5	14.8	5.5	YNE304	P.O.A.
GA50C40023EBA	23.4	11	18	7.5	YNE305	P.O.A.
GA50C40031EBA	31	15	24	11	YNE306	P.O.A.
GA50C40038EBA	38	18.5	31	15	YNE307	P.O.A.
GA50C40044EBA	44	22	39	18.5	YNE308	P.O.A.
GA50C40060EBA	60	30	45	22	YNE309	P.O.A.



HVAC



Winders



Punching Presses



Machine Tools



Compressors



Conveyors



Fans



Pumps



# YASKAWA NEW GA700 State of the Art Inverters IP20

## Limitless possibilities

**Incredibly reliable, easy to use, and powerful!**

YASKAWA have designed a variable speed drive to meet all your needs. Offering world class YASKAWA quality, along with intuitive interaction and high flexibility, the new **GA700** has absolutely endless application possibilities..!



**Features:**

- Dual Rated Constant & Variable Torque Application
- Flexible control panel mounting & cooling possibilities
- Intuitive keypad, navigation and startup Wizards
- Mobile connectivity via built in USB or optional bluetooth
- One drive for any induction, PM or SR motor
- Supports all major communications networks
- Integrated increased functional safety & reliability

**GA700 Inverter**

- o 0.55 – 355kW Power Ratings
- o 200VAC & 400VAC
- o 590Hz max output frequency
- o Built in DC reactor 22kW +
- o Braking Transistor to 75kW
- o EMC class C2 filter option
- o Coated PCB's

### Yaskawa GA700 Inverter - Three Phase 380 – 480V AC 50/60Hz - Category C3 Filter Built-In

Inverter Module	Normal Duty		Heavy Duty		Part No.	List Price £	Optional External Category C2 Filter		
	Amp	kW	Amp	kW			RFI Filter	Part No.	List Price £
GA70C4002BBA	2.1	0.75	1.8	0.55	YNE273	P.O.A.	FB-40008B	YNE110	P.O.A.
GA70C4004BBA	4.1	1.5	3.4	0.75	YNE274	P.O.A.	FB-40008B	YNE110	P.O.A.
GA70C4005BBA	5.4	2.2	4.8	1.5	YNE275	P.O.A.	FB-40008B	YNE110	P.O.A.
GA70C4007BBA	7.1	3.0	5.5	2.2	YNE276	P.O.A.	FB-40008B	YNE110	P.O.A.
GA70C4009BBA	8.9	4.0	7.2	3.0	YNE277	P.O.A.	FB-40014B	YNE114	P.O.A.
GA70C4012BBA	11.9	5.5	9.2	3.7	YNE278	P.O.A.	FB-40014B	YNE114	P.O.A.
GA70C4018BBA	17.5	7.5	14.8	5.5	YNE279	P.O.A.	FB-40025B	YNE116	P.O.A.
GA70C4023BBA	23.4	11	18	7.5	YNE280	P.O.A.	FB-40025B	YNE116	P.O.A.
GA70C4031BBA	31	15	24	11	YNE281	P.O.A.	FB-40044B	YNE118	P.O.A.
GA70C4038BBA	38	18.5	31	15	YNE282	P.O.A.	FB-40044B	YNE118	P.O.A.
GA70C4044BBA	44	22	39	18.5	YNE283	P.O.A.	FB-40060A	YNE120	P.O.A.
GA70C4060BBA	59.6	30	45	22	YNE284	P.O.A.	FB-40060A	YNE120	P.O.A.
GA70C4075BBA	74.9	37	60	30	YNE285	P.O.A.	FB-40072A	YNE119	P.O.A.
GA70C4089BBA	89.2	45	75	37	YNE286	P.O.A.	FB-40105A	YNE122	P.O.A.
GA70C4103BBA	103	55	91	45	YNE287	P.O.A.	FB-40105A	YNE122	P.O.A.
GA70C4140BBA	140	75	112	55	YNE288	P.O.A.	FB-40170A	YNE125	P.O.A.
GA70C4168BBA	168	90	150	75	YNE289	P.O.A.	FB-40170A	YNE125	P.O.A.
GA70C4208BBA	208	110	180	90	YNE290	P.O.A.	FB-40250A	YNE127	P.O.A.
GA70C4250BBA	250	132	216	110	YNE291	P.O.A.	FB-40250A	YNE127	P.O.A.
GA70C4296BBA	296	160	260	132	YNE292	P.O.A.	FB-40414A	YNE129	P.O.A.
GA70C4371BBA	371	200	304	160	YNE293	P.O.A.	FB-40414A	YNE129	P.O.A.
GA70C4389BBA	389	220	371	200	YNE294	P.O.A.	FB-40414A	YNE129	P.O.A.
GA70C4453BBA	453	250	414	220	YNE295	P.O.A.	FB-40675A	YNE111	P.O.A.
GA70C4568BBA	568	315	453	250	YNE296	P.O.A.	FB-40675A	YNE111	P.O.A.
GA70C4675BBA	675	355	605	315	YNE297	P.O.A.	FB-40675A	YNE111	P.O.A.

Flexibility, ease of use and a sustainable design for the best value proposition in your application

Full range of peripherals, options & accessories available...

Call us **NOW** for Technical Help and Pricing..!

# YASKAWA J1000 Inverters - IP20

Low cost variable speed drives



## Speed Control for Standard AC Induction Motor Applications

Including Pumps, Fans and Conveyors

### Features:

- Heavy Duty rating for Constant Torque Applications - for example Conveyors & Screw Feeders
- Normal Duty rating for Variable Torque Applications - for example Centrifugal Fans & Pumps
- Compact design and side by side mounting reduces installation and space costs
- Simple Digital Operator Keypad / Display with 8 keys & 5 digit LED display
- Easy Set-Up Functions for quick installation & operation
- Optional Remote LED Keypad / Display
- Serial Communication Option compatible with RS-422/485 Interface for MEMOBUS communication

### J1000 Inverter

- 0.1 - 5.5kW Power Ratings
- 200VAC & 400VAC
- 5 Digital Input
- 1 Analogue Input  
1 Analogue Output  
1 Relay output
- V/f control

Note:  
Normal Duty = 120% Overload for 60 seconds  
Heavy Duty = 150% Overload for 60 seconds

The footprint mounting RFI Filter is required for full EMC compliance.



### J1000 Inverter

Single Phase 200 - 240V AC 50/60Hz - IP20 Module + RFI Filter

Inverter Module	Normal Duty		Heavy Duty		Part Number	List Price £	RFI Filter	Part Number	List Price £
	Amp	kW	Amp	kW					
CIMR-JCBA0002BAA	1.9	0.4	1.6	0.2	YNE015	P.O.A.	FS23638-10-07	YNE019	P.O.A.
CIMR-JCBA0003BAA	3.5	0.75	3.0	0.4	YNE016	P.O.A.	FS23638-10-07	YNE019	P.O.A.
CIMR-JCBA0006BAA	6.0	1.1	5.0	0.75	YNE017	P.O.A.	FS23638-20-07	YNE022	P.O.A.
CIMR-JCBA0010BAA	9.6	2.2	8.0	1.5	YNE018	P.O.A.	FS23638-20-07	YNE022	P.O.A.

### J1000 Inverter

Three Phase 380 - 480V AC 50/60Hz - IP20 Module + RFI Filter

Inverter Module	Normal Duty		Heavy Duty		Part Number	List Price £	RFI Filter	Part Number	List Price £
	Amp	kW	Amp	kW					
CIMR-JC4A0001BAA	1.2	0.4	1.2	0.2	YNE000	P.O.A.	FS23639-5-07	YNE007	P.O.A.
CIMR-JC4A0002BAA	2.1	0.75	1.8	0.4	YNE001	P.O.A.	FS23639-5-07	YNE007	P.O.A.
CIMR-JC4A0004BAA	4.1	1.5	3.4	0.75	YNE002	P.O.A.	FS23639-5-07	YNE007	P.O.A.
CIMR-JC4A0005BAA	5.4	2.2	4.8	1.5	YNE003	P.O.A.	FS23639-10-07	YNE010	P.O.A.
CIMR-JC4A0007BAA	6.9	3.0	5.5	2.2	YNE004	P.O.A.	FS23639-10-07	YNE010	P.O.A.
CIMR-JC4A0009BAA	8.8	3.7	7.2	3.0	YNE005	P.O.A.	FS23639-10-07	YNE010	P.O.A.
CIMR-JC4A0011BAA	11.1	5.5	9.2	4.0	YNE006	P.O.A.	FS23639-15-07	YNE013	P.O.A.

Options	Description	Part Number	List Price £
JVOP-182	LED Operator Panel *	YNE027	P.O.A.
EUOP-V11001	Keypad IP65 Door Mounting Frame ***	YNE020	P.O.A.
RJ45 Plug Lead	Keypad Cable 1.5 meter	YNE021	P.O.A.
SI-485/J	Ser. Comm. Interf. RS 485	YNE023	P.O.A.
SI-232/J	Ser. Comm. Interf. RS 232-C	YNE024	P.O.A.
SI-232/JC	ditto RS232-C (removable)	YNE025	P.O.A.
AI-V3/J	Potentiometer	YNE026	P.O.A.
JVOP-181	Copy Unit w/USB converter **	YNE028	P.O.A.
EZZ08122A	DIN Rail Attachment 1	YNE029	P.O.A.
EZZ08122B	DIN Rail Attachment 2	YNE030	P.O.A.
EZZ08122C	DIN Rail Attachment 3	YNE154	P.O.A.

\* Requires SI-232/J (YNE024)  
\*\* Requires SI-232/JC (YNE025)  
\*\*\* Requires Keypad Cable (YNE021)

Call us **NOW** for Technical Help and Pricing..!

# YASKAWA V1000 Inverter - IP20

## V1000 Inverter

- 0.1 - 15kW Power Ratings
- 200VAC & 400VAC
- 6 Digital Input
  - 1 Pulse Input
  - 2 Analogue Input
- 1 Pulse Output
  - 1 Analogue Output
  - 1 Relay Output
- Safety EN 954-1 cat 3



## The One for All Inverter for Multiple Applications

Including all types of Pumps, Fans, Conveyors, Compressors, Mixers and more...

### Features

- Heavy Duty rating for Constant Torque Applications - for example Conveyors & Screw Feeders
- Normal Duty rating for Variable Torque Applications - for example Centrifugal Fans & Pumps
- **All the features of the J1000 plus more including:**
- Selectable Control Method: Open-Loop Current Vector or simple V/f
- Standard AC Induction Motor or Energy Saving Permanent Magnet Motor Control
- Application parameter pre-settings shorten set-up time
- Energy Saving Mode, PID control, Sleep Function, Auto-tuning,
- Dual Safety Input: safety category 3 (EN954-1), stop category) and IEC-61508 SIL2

## V1000 Inverter

Single Phase 200 - 240V AC 50/60Hz - IP20 Module + RFI Filter



Inverter Module	Normal Duty		Heavy Duty		Part Number	List Price £	RFI Filter	Part Number	List Price £
	Amp	kW	Amp	kW					
CIMR-VCBA0001BAA	1.2	0.2	0.8	0.1	YNE053	P.O.A.	FS23638-10-07	YNE019	P.O.A.
CIMR-VCBA0002BAA	1.9	0.4	1.6	0.2	YNE054	P.O.A.	FS23638-10-07	YNE019	P.O.A.
CIMR-VCBA0003BAA	3.3	0.75	3.0	0.4	YNE055	P.O.A.	FS23638-10-07	YNE019	P.O.A.
CIMR-VCBA0006BAA	6.0	1.1	5.0	0.75	YNE056	P.O.A.	FS23638-20-07	YNE022	P.O.A.
CIMR-VCBA0010BAA	9.6	2.2	8.0	1.5	YNE057	P.O.A.	FS23638-20-07	YNE022	P.O.A.
CIMR-VCBA0012BAA	12.0	3.1	11.0	2.2	YNE058	P.O.A.	FS23638-30-07	YNE065	P.O.A.
CIMR-VCBA0018BAA	-	-	17.5	4.0	YNE059	P.O.A.	FS23638-40-07	YNE066	P.O.A.

Note: Normal Duty = 120% Overload for 60 seconds  
 Heavy Duty = 150% Overload for 60 seconds  
 The footprint mounting RFI Filter is required for full EMC compliance.

## V1000 Inverter

Three Phase 380 - 480V AC 50/60Hz - IP20 Module + RFI Filter

Inverter Module	Normal Duty		Heavy Duty		Part Number	List Price £	RFI Filter	Part Number	List Price £
	Amp	kW	Amp	kW					
CIMR-VC4A0001BAA	1.2	0.4	1.2	0.2	YNE031	P.O.A.	FS23639-5-07	YNE007	P.O.A.
CIMR-VC4A0002BAA	2.1	0.75	1.8	0.4	YNE032	P.O.A.	FS23639-5-07	YNE007	P.O.A.
CIMR-VC4A0004BAA	4.1	1.5	3.4	0.75	YNE033	P.O.A.	FS23639-5-07	YNE007	P.O.A.
CIMR-VC4A0005BAA	5.4	2.2	4.8	1.5	YNE034	P.O.A.	FS23639-10-07	YNE010	P.O.A.
CIMR-VC4A0007BAA	6.9	3.0	5.5	2.2	YNE035	P.O.A.	FS23639-10-07	YNE010	P.O.A.
CIMR-VC4A0009BAA	8.8	3.7	7.2	3.0	YNE036	P.O.A.	FS23639-10-07	YNE010	P.O.A.
CIMR-VC4A0011BAA	11.1	5.5	9.2	4.0	YNE037	P.O.A.	FS23639-15-07	YNE013	P.O.A.
CIMR-VC4A0018FAA	17.5	7.5	14.8	5.5	YNE038	P.O.A.	FS23639-30-07	YNE049	P.O.A.
CIMR-VC4A0023FAA	23.0	11.0	18.0	7.5	YNE039	P.O.A.	FS23639-30-07	YNE049	P.O.A.
CIMR-VC4A0031FAA	31.0	15.0	24.0	11.0	YNE040	P.O.A.	FS23639-50-07	YNE051	P.O.A.
CIMR-VC4A0038FAA	38.0	18.5	31.0	15.0	YNE041	P.O.A.	FS23639-50-07	YNE051	P.O.A.

Options	Description	Part Number	List Price £
JVOP-180	Separate LCD Operator Panel	YNE087	P.O.A.
JVOP-182	Separate LED Operator Panel	YNE027	P.O.A.
EUOP-V11001	Keypad IP65 Door Mounting Frame ***	YNE020	P.O.A.
RJ45 Plug Lead	Keypad Cable 1.5 meter	YNE021	P.O.A.
PS-V105	ext.24V power supply upto 4kW	YNE080	P.O.A.
PS-V10M	ext.24V power supply 5.5-15kW	YNE081	P.O.A.
SI-C3/V	Comm.Interface CC Link	YNE082	P.O.A.
SI-N3/V	Comm.Interface DeviceNet	YNE083	P.O.A.
SI-P3/V	Comm.Interface Profibus DP	YNE084	P.O.A.
SI-S3/V	Comm.Interface CANopen	YNE085	P.O.A.
SI-T3/V	Comm.Interface Mechatrolink II	YNE086	P.O.A.
JVOP-181	Copy Unit RS232/USB	YNE028	P.O.A.
EZZ08122A	DIN Rail Attachment 1	YNE029	P.O.A.
EZZ08122B	DIN Rail Attachment 2	YNE030	P.O.A.
EZZ08122C	DIN Rail Attachment 3	YNE154	P.O.A.
EZZ08122D	DIN Rail Attachment 4	YNE155	P.O.A.
SI-EL3/V	Comm.Interface V1000 Powerlink	YNE233	P.O.A.
SI-EN3/V	Comm.Interface V1000 Ethernet IP	YNE234	P.O.A.
SI-EN3D/V	Comm.Interface V1000 Dual Port Ethernet IP	YNE235	P.O.A.
SI-EM3/V	Comm.Interface V1000 Modbus TCP	YNE236	P.O.A.
SI-EP3/V	Comm.Interface V1000 ProfiNet	YNE237	P.O.A.
EUOP-SI-ES3/V	Comm.Interface V1000 EtherCAT	YNE238	P.O.A.

\*\*\*Requires Keypad Cable (YNE021)



# YASKAWA A1000 Inverter - IP20/IP00



## High Performance Inverter

Offering the widest range of control possibilities from Simple to Advanced Vector

### Features

- Heavy Duty rating for Constant Torque Applications
- Normal Duty rating for Variable Torque Applications
- Integral Detachable LCD Operator Keypad/Display
- Closed-Loop Current Vector, Open-loop Vector & V/f Control modes
- Powerful Torque at 0 Hz without sensors or feedback devices
- Application Presets, Advanced Energy Saving, Power Loss Ride Through & Recovery, "Safe Torque Off" functional safety
- Multiple options available for comprehensive application performance & complex control



### A1000 Inverter

- 0.4 - 630kW Power Ratings
- 200VAC & 400VAC
- 8 Digital Input
  - 1 Pulse Input
  - 3 Analogue Input
- 1 Pulse Output
  - 2 Analogue Output
  - 3 Relay Output
- Advanced Open Loop Vector
  - Closed Loop Vector
- PM-, SPM-, & IPM Motor Control
- Safety EN 954-1 cat 3, EN 61508 SIL2

## A1000 Inverter

Three Phase 380- 480V AC 50/60Hz - Module + RFI Filter

Inverter Module	Normal Duty		Heavy Duty		Part No.	List Price £	IP20 Kit*		IP20 Kit*		Part No.	List Price £
	Amp	kW	Amp	kW			Part Number	List Price £	RFI Filter	List Price £		
CIMR-AC4A0002FAA	2.1	0.75	1.8	0.55	YNE089	P.O.A.	IP20 Standard	P.O.A.	FB-40008A	YNE110	P.O.A.	
CIMR-AC4A0004FAA	4.1	1.5	3.4	0.75	YNE090	P.O.A.	IP20 Standard	P.O.A.	FB-40008A	YNE110	P.O.A.	
CIMR-AC4A0005FAA	5.4	2.2	4.8	1.5	YNE091	P.O.A.	IP20 Standard	P.O.A.	FB-40008A	YNE110	P.O.A.	
CIMR-AC4A0007FAA	6.9	3.0	5.5	2.2	YNE092	P.O.A.	IP20 Standard	P.O.A.	FB-40008A	YNE110	P.O.A.	
CIMR-AC4A0009FAA	8.8	4.0	7.2	3.0	YNE093	P.O.A.	IP20 Standard	P.O.A.	FB-40014A	YNE114	P.O.A.	
CIMR-AC4A0011FAA	11.1	5.5	9.2	4.0	YNE094	P.O.A.	IP20 Standard	P.O.A.	FB-40014A	YNE114	P.O.A.	
CIMR-AC4A0018BAA	17.5	7.5	14.8	5.5	YNE095	P.O.A.	IP20 Standard	P.O.A.	FB-40025A	YNE116	P.O.A.	
CIMR-AC4A0023FAA	23.0	11.0	18.0	7.5	YNE096	P.O.A.	IP20 Standard	P.O.A.	FB-40025A	YNE116	P.O.A.	
CIMR-AC4A0031FAA	31.0	15.0	24.0	11.0	YNE097	P.O.A.	IP20 Standard	P.O.A.	FB-40044A	YNE118	P.O.A.	
CIMR-AC4A0038FAA	38.0	18.5	31.0	15.0	YNE098	P.O.A.	IP20 Standard	P.O.A.	FB-40044A	YNE118	P.O.A.	
CIMR-AC4A0044FAA	44.0	22.0	39.0	18.5	YNE099	P.O.A.	IP20 Standard	P.O.A.	FB-40060A	YNE120	P.O.A.	
CIMR-AC4A0058AAA	58.0	30.0	45.0	22.0	YNE100	P.O.A.	YNE121	P.O.A.	FB-40060A	YNE120	P.O.A.	
CIMR-AC4A0072AAA	72.0	37.0	60.0	30.0	YNE101	P.O.A.	YNE123	P.O.A.	FB-40072A	YNE119	P.O.A.	
CIMR-AC4A0088AAA	88.0	45.0	75.0	37.0	YNE102	P.O.A.	YNE124	P.O.A.	FB-40105A	YNE122	P.O.A.	
CIMR-AC4A0103AAA	103.0	55.0	91.0	45.0	YNE103	P.O.A.	YNE124	P.O.A.	FB-40105A	YNE122	P.O.A.	
CIMR-AC4A0139AAA	139.0	75.0	112.0	55.0	YNE104	P.O.A.	YNE126	P.O.A.	FB-40170A	YNE125	P.O.A.	
CIMR-AC4A0165AAA	165.0	90.0	150.0	75.0	YNE105	P.O.A.	YNE126	P.O.A.	FB-40170A	YNE125	P.O.A.	
CIMR-AC4A0208AAA	208.0	110.0	180.0	90.0	YNE106	P.O.A.	YNE128	P.O.A.	FB-40250A	YNE127	P.O.A.	
CIMR-AC4A0250AAA	250.0	132.0	216.0	110.0	YNE107	P.O.A.	YNE128	P.O.A.	FB-40250A	YNE127	P.O.A.	
CIMR-AC4A0296AAA	296.0	160.0	260.0	132.0	YNE108	P.O.A.	YNE130	P.O.A.	FB-40414A	YNE129	P.O.A.	
CIMR-AC4A0362AAA	362.0	185.0	304.0	160.0	YNE109	P.O.A.	YNE130	P.O.A.	FB-40414A	YNE129	P.O.A.	

Options	Description	Part No.	List Price £
JVOP-180	Separate LCD Operator Panel	YNE087	P.O.A.
JVOP-182	Separate LED Operator Panel	YNE027	P.O.A.
EUOP-V11001	Keypad IP65 Door Mounting Frame ***	YNE020	P.O.A.
RJ45 Plug Lead	Keypad Cable 1.5 meter	YNE021	P.O.A.
AI-A3	Analogue Input	YNE131	P.O.A.
AO-A3	Analogue Output	YNE132	P.O.A.
DI-A3	Digital Input	YNE133	P.O.A.
DO-A3	Digital Output	YNE134	P.O.A.
PG-B3	TTL Interface 30kHz	YNE135	P.O.A.
PG-X3	Line Driver Interface 300kHz	YNE136	P.O.A.
SI-C3	Comm. Interface CCLink	YNE137	P.O.A.
SI-N3	Comm. Interface DeviceNET	YNE138	P.O.A.
SI-P3	Comm. Interface ProfibusDP	YNE139	P.O.A.
SI-S3	Comm. Interface CANopen	YNE140	P.O.A.
SI-T3	Comm. Interface Mechatrolink II	YNE141	P.O.A.
PS-A10H	Power Supply Unit 24VDC (400V)	YNE142	P.O.A.
PS-A10L	Power Supply Unit 24VDC (200V)	YNE143	P.O.A.
CDBR-4030B	400V Braking Transistor Unit 30kW	YNE148	P.O.A.
CDBR-4045B	400V Braking Transistor Unit 30kW	YNE149	P.O.A.
CDBR-4090B	400V Braking Transistor Unit 30kW	YNE150	P.O.A.
CDBR-4220B	400V Braking Transistor Unit 30kW	YNE151	P.O.A.
SI-EL3	Comm.Interface V1000 Powerlink	YNE239	P.O.A.
SI-EN3	Comm.Interface V1000 Ethernet IP	YNE240	P.O.A.
SI-EN3D	Comm.Interface V1000 Dual Port Ethernet IP	YNE241	P.O.A.
SI-EM3	Comm.Interface V1000 Modbus TCP	YNE242	P.O.A.
SI-EP3	Comm.Interface V1000 ProfiNet	YNE243	P.O.A.
EUOP-SI-ES3	Comm.Interface V1000 EtherCAT	YNE244	P.O.A.

\* IP20 Standard up to CIMR - AC4A0044 FAA  
IP00 Standard up to CIMR - AC4A0058 AAA or  
IP20 With optional kit shown

**Note:**

Normal Duty = 120% Overload for 60 seconds  
Heavy Duty = 150% Overload for 60 seconds

50/60Hz - Module + RFI Filter

The footprint mounting RFI Filter is required for full EMC compliance.

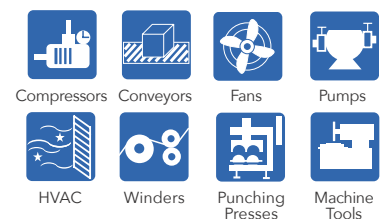

\*\*\* Requires Keypad Cable (YNE021)



# YASKAWA V1000 Enclosed Wall Mount Inverter - IP66

(Max 18.5kW)

## Compact V1000 based Drive Units with IP66 Protection for Wet & Dusty Harsh Environments

### Features:

- All the functions and benefits of the standard V1000 inverter plus
- Robust, highly sealed and protected enclosure for arduous decentralised locations
- Built in oversize LED Operator Keypad/Display for easy reading and handling
- Integrated Class C1 EMC filter

### V1000 Enclosed Inverter - IP66

Three Phase 380-480V AC 50/60Hz with integral RFI Filter

Enclosed Inverter Model	Normal Duty		Heavy Duty		Dimensions (mm)			Part Number	List Price £
	Amp	kW	Amp	kW	Height	Width	Depth		
CIMR-VC4A0001HAA-0080	1.2	0.4	1.2	0.2	340	262	173.5	YNE067	P.O.A.
CIMR-VC4A0002HAA-0080	2.1	0.75	1.8	0.4	340	262	173.5	YNE068	P.O.A.
CIMR-VC4A0004HAA-0080	4.1	1.5	3.4	0.75	340	262	173.5	YNE069	P.O.A.
CIMR-VC4A0005HAA-0080	5.4	2.2	4.8	1.5	340	262	173.5	YNE070	P.O.A.
CIMR-VC4A0007HAA-0080	6.9	3	5.5	2.2	340	262	173.5	YNE071	P.O.A.
CIMR-VC4A0009HAA-0080	8.8	3.7	7.2	3.0	340	262	173.5	YNE072	P.O.A.
CIMR-VC4A0011HAA-0080	11.1	5.5	9.2	4.0	340	262	173.5	YNE073	P.O.A.
CIMR-VC4A0018HAA-0080	17.1	7.5	14.8	5.5	500	500	273.5	YNE008	P.O.A.
CIMR-VC4A0023HAA-0080	23.0	11.0	18.0	7.5	500	500	273.5	YNE009	P.O.A.
CIMR-VC4A0031HAA-0080	31.0	15.0	24.0	11.0	500	500	273.5	YNE011	P.O.A.
CIMR-VC4A0038HAA-0080	38.0	18.5	31.0	15.0	500	500	273.5	YNE012	P.O.A.



## A1000 High Performance Enclosed Wall Mounted Inverter - IP54

(18.5kW - 75kW)

### Features:

- All the functions and benefits of the standard A1000 inverter plus
- Compact IP54 protected enclosure for demanding decentralised installations
- Integral clear text LCD Operator Keypad/Display in 8 languages
- Integrated Class C1 EMC filter
- Lockable Mains Switch option



## A1000 IP54 Enclosed Inverter

Three Phase 380-480V AC 50/60Hz with integral RFI Filter

Inverter Model	Normal Duty		Amp	kW	Height	Width	D1	D(2)	No Isolator		With Isolator	
	Amp	kW							Part Number	List Price £	Part Number	List price £
CIMR-AC4A0044TAA*	44	22	39	18.5	700	400	260	(292)	YNE042	P.O.A.	YNE050	P.O.A.
CIMR-AC4A0058TAA*	58	30	45	22	750	465	300	(331)	YNE043	P.O.A.	YNE052	P.O.A.
CIMR-AC4A0072TAA*	72	37	60	30	750	465	300	(331)	YNE044	P.O.A.	YNE060	P.O.A.
CIMR-AC4A0088TAA*	88	45	75	37	950	555	325	(375)	YNE045	P.O.A.	YNE061	P.O.A.
CIMR-AC4A0103TAA*	103	55	91	45	950	555	325	(375)	YNE046	P.O.A.	YNE062	P.O.A.
CIMR-AC4A0139TAA*	139	75	112	55	950	555	325	(375)	YNE047	P.O.A.	YNE063	P.O.A.
CIMR-AC4A0165TAA*	165	90	150	75	950	555	325	(375)	YNE048	P.O.A.	YNE064	P.O.A.

\* Note: For Mains Switch version "0095" completes model code and the YNE Part No. specifies type

\*\* Note: "D2" Dimensions in brackets relate to with Mains Switch version

Call us **NOW** for Technical Help and Pricing..!

# YASKAWA Floor Standing Enclosed A1000 Inverters

(90kW - 315kW)

**Features:**

- Higher power cabinet build on request
- Free standing 90 – 315kW modular design
- IP23 or IP54 cubicle protection options
- Customisation panel extra for special requirements
- Product configured & Price available on request



## Z1000 HVAC Inverters

The Z1000 variable speed drive is specifically designed for HVAC building automation applications such as fans, pumps, and cooling towers. Dedicated features include an easy-to-read LCD keypad with a Hand-Off-Auto interface and a real time clock.

**Other Features**

- Built-in 5% line impedance for input harmonic reduction
- Built-in RFI filter to IEC 61800-3 restricted distribution for first environments
- Embedded BACnet communications with Modbus/Memobus
- PI feature for pressure, flow or temperature control
- Low 5kHz carrier frequency with dynamic noise control for quiet motor operation
- Pre-configured application macros for quick and easy set up

Normal Duty rated with an Overload of 110% of rated output current for 60s or 140% of rated output current for 0.5s.

**Z1000 prices are on application** - please contact us to discuss your requirements for these or any of the above inverter modules and complete panel systems for process control or energy saving...



Call us **NOW** for Technical Help and Pricing..!



# YASKAWA Standard Inverter Panels - IP54

A Standard range of inverter drive cubicles pre-engineered for immediate installation...

Complete with the NEW Yaskawa V1000 & A1000 inverter modules..!

## V1000 Single Phase IP54 Standard Drive Panel

Single Phase 230V 50/60Hz Supply to Three Phase 230V Output

Part Number	Normal Duty		Heavy Duty		Approximate Panel Size (mm)			List Price £
	Amp	kW	Amp	kW	Height	Width	Depth	
VCBA0001	1.2	0.2	0.18	0.1	500	400	300*	P.O.A.
VCBA0002	1.9	0.4	1.6	0.2	500	400	300*	P.O.A.
VCBA0003	3.3	0.75	3.0	0.4	600	400	300*	P.O.A.
VCBA0006	6.0	1.5	5.0	0.75	600	400	300*	P.O.A.
VCBA0010	9.6	2.2	8.0	1.5	600	400	300*	P.O.A.
VCBA0012	12.0	3.0	11.0	2.2	600	400	300*	P.O.A.
VCBA0018			17.5	4.0	600	400	300*	P.O.A.

## V1000 Three Phase IP54 Standard Drive Panel

Three Phase 380-480V AC 50/60Hz with integral RFI Filter

Part Number	Normal Duty		Heavy Duty		Approximate Panel Size (mm)			List Price £
	Amp	kW	Amp	kW	Height	Width	Depth	
VC4A0001	1.2	0.4	1.2	0.2	500	400	200*	P.O.A.
VC4A0002	2.1	0.75	1.8	0.4	500	400	200*	P.O.A.
VC4A0004	4.1	1.5	3.4	0.75	600	400	300*	P.O.A.
VC4A0005	5.4	2.2	4.8	1.5	600	400	300*	P.O.A.
VC4A0007	6.9	3.0	5.5	2.2	600	400	300*	P.O.A.
VC4A0009	8.8	4.0	7.2	3.0	600	400	300*	P.O.A.
VC4A0011	11.1	5.5	9.2	4.0	600	600	300*	P.O.A.
VC4A0018	17.5	7.5	14.8	5.5	800	600	300*	P.O.A.
VC4A0023	23.0	11.0	18.0	7.5	800	600	300*	P.O.A.
VC4A0031	31.0	15.0	24.0	11.0	800	600	300*	P.O.A.
VC4A0038	38.0	18.5	31.0	15.0	800	600	300*	P.O.A.

## A1000 Three Phase IP54 Standard Drive Panel

Three Phase 400V 50/60Hz supply to Three Phase 400V output

Part Number	Normal Duty		Heavy Duty		Approximate Panel Size (mm)			List Price £
	Amp	kW	Amp	kW	Height	Width	Depth	
AC4A0044	44	22	39	18.5	1000	800	300*	P.O.A.
AC4A0058	58	30	45	22	1200	800	400*	P.O.A.
AC4A0072	72	37	60	30	1200	800	400*	P.O.A.
AC4A0088	88	45	75	37	1600	800	400**	P.O.A.
AC4A0103	103	55	91	45	1600	800	400**	P.O.A.
AC4A0139	139	75	112	55	1800	1000	400**	P.O.A.
AC4A0165	165	90	150	75	1800	1000	400**	P.O.A.
AC4A0208	208	110	180	90	1800	1200	500**	P.O.A.
AC4A0250	250	132	216	110	1800	1200	500**	P.O.A.
AC4A0296	269	160	260	132	1800	1600	500**	P.O.A.

\* Wall Mounting

\*\* Floor Mounting

Note:- Normal Duty = 120% Overload for 60 seconds, Heavy Duty = 150% Overload for 60 seconds

Please refer to pages 49 & 50 for the complete drives specification and range of common and application options available.

All cubicle dimensions are approximate only and may be affected where further options or tailored solutions are required, please consult us with your exact requirements.

### Features:

- Single or three phase versions
- Standard control features
- Supplied ready to install
- Tailored solutions available on request

For standard speed control of Pumps, Fans, Compressors, Mixers, Screw Conveyors and more...



### Technical Specification:

- Robust IP54 sheet steel enclosure
- Inverter Module with EMC filtering
- Ventilation cooling fans and filters where rating requires
- Door interlocked mains isolator
- Supply Contactor with power On/Off push buttons
- Inverter Start/Stop push buttons
- Speed potentiometer.
- Mains on lamp
- Emergency stop (Category 1) - via mains contactor
- Door mounted operator display

### Available on request:

- Additional control functionality
- Dynamic Braking
- Serial Communications
- Stainless Steel or preferred paint finish
- Larger enclosures
- Fully customised drive systems

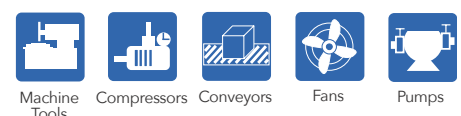

**Getting Started - How to code a Standard Starter...**

1. Starter Type	
3DL	Direct-on-Line (D.O.L.)
3DR	Direct-on-Line Reversing
3SD	Star Delta (S.D.)
3DW	Dual Wound
3PC	Pole Change
3SP	Series Parallel
3DS	Duty Standby
3FS	Fan Shaker
3EBS	Enclosures only
3DC	3 Phase DOL DC Brake
3DP	1 Phase DOL DC Brake
3DY	Star Delta DC Brake
3SG	Spinguard
3DLF	ATEX Direct-on-Line
3SDF	ATEX Star-Delta

**Example Starter Code**  
 400kW Star Delta Starter 400V, 3p, 50Hz,  
 normal start with 100% torque,  
 Ammeter, 5 Terminal Overload range 31-43 amps cc  
**3SD3ENI/04**



2. Main Contactor					
Code	Maximum Power (kW)	Full Load Current (A)			
		3-Phase	2-Phase	1-Phase	
1	CC09	5.5	12	11	21
2	CC12	7.5	18	15	30
3	CC18	11.0	25	22	43
4	CC25	15.0	32	30	55
A5	CC32	18.5	40	37	69
5 (05 for 3SD)	CC40	26.0	50	45	85
6 (06 for 3SD)	CC50	30.0	55	55	98
07	CC65	37.0	80	75	138
08	CC80	55.0	100	90	160
09	CCM150	75.0	140	110	208
10	CCM180	90.0	180	150	250
11	CCM250	110.0	200	200	346
12	CCM250	132.0	220	220	380

3. Contactor Coil Voltage & Hz			
Code	Volt	Hz	Code
A	110		
C	230		
D	24		
E	400		
F	440		
I	48		
Special	Voltage	Special	Voltage
B	120	M	277
X	380	P	208
R	220	U	600
S	480		
Q	240		
W	575		
Y	415		

6. Extra Features Suffix Codes	
01	Stop/Reset Only
02	Press to Run
03	Hand/Off/Auto Selector
04	Ammeter
05	Separate Control Circuit
06	Control Transformer
07	Line to Neutral Control
08	Motor Running Lamp
09	Anti-Condensation Heater
10	Single Phase Mains Wiring
11	Single Phase & Stop Reset
12	Single Phase & Press to Run
13	Single Phase & Hand/Off/Auto
14	Single Phase & Ammeter
15	Single Phase & Separate Control Circuit
16	Single Phase & Control Transformer
17	Single Phase & Motor Run Lamp
18	Single Phase & Anti-Condensation Heater

5. Variations	
S	Standard
I	With Isolator
F	With Isolator and Mains Fuses / Switch Fuse*
L	With Mains Fuses
P	Plastic Enclosure
U	Un-enclosed (Interior Only)

\*Hinged Door Enclosure - Switch Fuse Fitted

Typical Motor Currents (amps)					
Motor Power (kW)	Rating	Full Load Current (A)			
		3-Phase	2-Phase	1-Phase	1-Phase
0.095	1/4	1.34	1.23	0.435	0.398
0.125	1/4	1.69	1.55	0.541	0.495
0.150	1/4	1.96	1.79	0.614	0.562
0.190	1/4	2.32	2.13	0.718	0.657
0.250	1/2	2.9	2.68	0.87	0.795
0.375	1/2	3.88	3.56	1.15	1.05
0.600	3/4	5.2	4.77	1.58	1.44
0.750	1	6.59	6.04	1.95	1.78
1.1	1 1/2	9.6	8.8	2.75	2.51
1.5	2	12.7	11.7	3.55	3.24
1.9	2 1/2	15.7	14.4	4.34	3.97
2.2	3	18.6	17.1	5.11	4.68
3	4	24.3	22.2	6.66	6.1
3.7	5	29.6	27.1	8.22	7.54
4.5	6	34.7	31.8	9.75	8.92
5.2	7	39.8	36.5	11.3	10.4
5.6	7 1/2	42.2	38.7	12	11
6	8	44.5	40.8	12.8	11.7
6.7	9	49.5	45.4	14.3	13.1
7.5	10	54.4	50.0	15.8	14.5
9.3	12 1/2			19.6	17.9
11	15			23.3	21.3
15	20			30.7	28
18.5	25			38	34.8
22	30			45.1	41.3
26	35			52.5	48
30	40			59.6	54.6
34	45			67	61.3
37.5	50			74.1	67.9
45	60			88.4	80.9
52.5	70			103	94
56	75			110	100
60	80			117	107
67.5	90			131	120
75	100			145	133

4. Overload Range			
Code	CR Rating	Motor Overload Range	Motor Contactors
X	0.16 - 0.25A		CR09/0.25 CC09 to CC32
A	0.25 - 0.4A		CR09/0.4 CC09 to CC32
B	0.4 - 0.63A		CR09/0.63 CC09 to CC32
D	0.63 - 1.0A		CR09/1 CC09 to CC32
E	1.0 - 1.6A		CR09/1.6 CC09 to CC32
F	1.6 - 2.5A	2.7 - 4.3A	CR09/2.5 CC09 to CC32
G	2.5 - 4.0A	4.3 - 6.9A	CR09/4 CC09 to CC32
H	4.0 - 6A	6.9 - 10.4A	CR09/6 CC09 to CC32
J	5.5 - 8A	9.5 - 13.8A	CR09/8 CC09 to CC32
K	7.0 - 10A	12 - 17A	CR09/10 CC09 to CC32
L	10 - 13A	17 - 22A	CR12/13 CC09 to CC32
M	13 - 18A	22 - 31A	CR16/18 CC09 to CC32
N	18 - 25A	31 - 43A	CR25/25 CC09 to CC32
C	23 - 32A	39 - 55A	CR32/32 CC25 to CC32
Q	28 - 40A	48 - 69A	CR32/40 CC25 to CC32
R	23 - 32A	39 - 55A	CR40/32 CC40 to CC65
S	30 - 40A	51 - 69A	CR40/40 CC40 to CC65
T	38 - 50A	65 - 86A	CR63/50 CC40 to CC65
U	48 - 57A	83 - 98A	CR63/57 CC40 to CC65
V	57 - 66A	98 - 114A	CR63/66 CC40 to CC65
W	63 - 80A	109 - 138A	CRA80/80 CC40 to CC80
P	80 - 93A	138 - 161A	CRA80/93 CC40 to CC80
Y	Thermister Protection		
Z	Without Overload Fitted (Wiring for loose O/L to be fitted)		

Higher Thermal Overload Ranges available on request.

- 1 Method of Starting
- 2 Contactor size to cover Motor Power (kW's) and Full Load Current
- 3 Control Circuit Voltage and Frequency (Hz)
- 4 Overload Range to cover Motor Full Load Current  
*Note: Different Ratings for Direct-On-Line & Star Delta*
- 5 Starter Style
- 6 Extras



## Definition of Degrees of Protection

The designation used for the degree of protection consists of the letters IP followed by two numerals signifying conformity with the conditions stated in the table.

Designation	First Numeral Protection against contact and against ingress of solid objects	Second Numeral Protection against ingress of water	General Description
IP21	Protection against contact by finger with electrically live parts inside the enclosure and against solid objects with a diameter greater than 12mm.	Dripping water falling vertically	<b>Drip Proof</b>
IP22		Dripping water falling at an angle up to 15° from the vertical	
IP23		Water falling as a spray at an angle up to 60° from the vertical.	
IP31	Protected against ingress of solid objects with a diameter of more than 2.5 mm.	Dripping water falling vertically	<b>Enclosed</b>
IP44	Protection against contact with live or moving parts by tools, wires or other objects of a thickness greater than 1mm.	Water splashing against the machine from any angle shall have no harmful effect	<b>Totally Enclosed</b>
IP55	Complete protection against contact with live or moving parts. Protection against harmful deposits of dust. Dust does not accumulate in an amount sufficient to impair operation.	Water projected by the nozzle against the machine from any angle shall have no harmful effect	<b>Totally Enclosed or Weatherproof or Dustproof or Hoseproof</b>
IP56		Water protected against conditions on a ships deck.	<b>Deck Watertight</b>
IP65	Totally protected against dust.	Water projected by the nozzle against the machine from any angle shall have no harmful effect	<b>Dust Tight</b>
IP66		Water protected against conditions on a ships deck.	<b>Dust &amp; Watertight</b>

## A Guide to Typical Currents (amps)

Motor Power Rating		Full Load Current (A)										
		Single Phase			Three Phase							
kW	HP	110V	220V	240V	220V	240V	346V	380V	415V	440V	500V	550V
0.095	1/8	2.69	1.34	1.23	0.751	0.689	0.478	0.435	0.398	0.376	0.331	0.3
0.125	1/6	3.38	1.69	1.55	0.935	0.855	0.593	0.541	0.495	0.466	0.411	0.372
0.150	1/5	3.91	1.96	1.79	1.06	0.971	0.675	0.614	0.562	0.53	0.466	0.424
0.190	1/4	4.66	2.32	2.13	1.24	1.14	0.788	0.718	0.657	0.62	0.545	0.495
0.250	1/3	5.80	2.9	2.68	1.50	1.37	0.955	0.87	0.795	0.75	0.66	0.6
0.375	1/2	7.77	3.88	3.56	1.98	1.82	1.26	1.15	1.05	0.99	0.871	0.792
0.600	3/4	10.4	5.2	4.77	2.72	2.5	1.73	1.58	1.44	1.36	1.20	1.09
0.750	1	13.2	6.59	6.04	3.36	3.09	2.14	1.95	1.78	1.68	1.48	1.34
1.1	1 1/2	19.2	9.6	8.8	4.75	4.35	3.02	2.75	2.51	2.37	2.09	1.9
1.5	2	25.4	12.7	11.7	6.12	5.61	3.89	3.55	3.24	3.06	2.7	2.45
1.9	2 1/2	31.5	15.7	14.4	7.5	6.88	4.76	4.34	3.97	3.75	3.3	3.0
2.2	3.0	37.3	18.6	17.1	8.83	8.1	5.61	5.11	4.68	4.42	3.88	3.53
3.0	4.0	48.3	24.3	22.2	11.5	10.6	7.32	6.66	6.1	5.77	5.07	4.61
3.7	5.0	59.2	29.6	27.1	14.2	13.0	9.04	8.22	7.54	7.1	6.25	5.69
4.5	6.0	69.4	34.7	31.8	16.9	15.4	10.7	9.75	8.92	8.41	7.40	6.73
5.2	7.0	79.6	39.8	36.5	19.5	17.9	12.4	11.3	10.4	9.75	8.59	7.8
5.6	7 1/2	84.4	42.2	38.7	20.8	19.1	13.2	12.0	11.0	10.4	9.15	8.31
6.0	8.0	89.0	44.5	40.8	22.1	20.2	14.0	12.8	11.7	11.0	9.7	8.81
6.7	9.0	99.0	49.5	45.4	24.6	22.6	15.7	14.3	13.1	12.3	10.8	9.84
7.5	10.0	109.0	54.4	50.0	27.3	25.0	17.4	15.8	14.5	13.7	12.0	10.9
9.3	12 1/2				33.8	31.0	21.5	19.6	17.9	16.9	14.9	13.5
11.0	15.0				40.1	36.8	25.5	23.3	21.3	20.1	17.7	16.1
15.0	20.0				53.0	48.5	33.7	30.7	28.0	26.5	23.3	21.2
18.5	25.0				65.6	60.1	41.7	38.0	34.8	32.8	28.9	26.3
22.0	30.0				78.1	71.5	49.6	45.1	41.3	39.0	34.4	31.2
26.0	35.0				90.6	83.1	57.6	52.5	48.0	45.3	39.9	36.3
30.0	40.0				103.0	94.5	65.5	59.6	54.6	51.5	45.3	41.2
34.0	45.0				116.0	106.0	73.5	67.0	61.3	57.9	50.9	48.3
37.5	50.0				128.0	117.0	81.3	74.1	67.9	64.0	56.4	51.2
45.0	60.0				153.0	140.0	97.0	88.4	80.9	76.3	67.1	61.0
52.5	70.0				177.0	163.0	113.0	103.0	94.0	88.5	77.9	70.9
56.0	75.0				189.0	174.0	120.0	110.0	100.0	94.6	83.4	75.7
60.0	80.0				202.0	185.0	128.0	117.0	107.0	101.0	88.5	80.5
67.5	90.0				227.0	208.0	144.0	131.0	120.0	113.0	99.8	90.7
75.0	100.0				251.0	230.0	159.0	145.0	133.0	125.0	110.0	100.0

## Extras for Motor Starters

Description	Enclosure	List Price £	Description	Enclosure	List Price £
Small ammeter to 40A FLC	Pressed	P.O.A.	Mushroom Head Stop	Pressed	P.O.A.
Ammeter under 70A FLC	All Types	P.O.A.	Latching Stop/Lock	All Types	P.O.A.
Ammeter above 70A FLC	All Types	P.O.A.	Thermistor Unit in place		
Volt Meter	All Types	P.O.A.	of Thermal Overload	Pressed	P.O.A.
Control Transformer	Pressed	P.O.A.	Hand/Off/Auto Switch	Pressed	P.O.A.
Anti Condensation Heater	Pressed	P.O.A.	Hours Run Meter	All Types	P.O.A.
Anti Condensation Heater	Hinged	P.O.A.	External Overload Reset	Hinged	P.O.A.
Neon Indicator up to 230V	Pressed	P.O.A.	Chassis Interiors Only	All Types	P.O.A.
Filament Lamp up to 230V	All Types	P.O.A.	Emergency Stop Button	All Types	P.O.A.

## Slatwall Displays

POINTS OF SALE for the Serious Stockist!

To find out more call our offices and ask for our point of sale brochure...

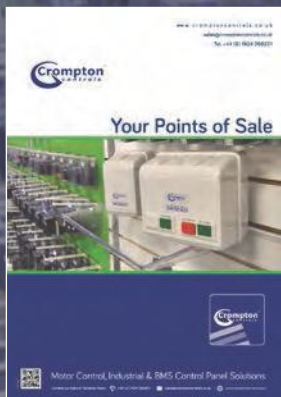

 Call us **NOW** for Technical Help and Pricing..!



The Original Spoola Plus Cable Carrier will hold up to 50KG of cable..!

Call us: 01924 368251

Or visit our website for details

[cromptoncontrols.co.uk](http://cromptoncontrols.co.uk)



## Did You Know we do Panel Mount Isolators?

Loose Components OR Fully Enclosed - *AND don't forget your Lockout Kits!*

# Make the Switch

AC Isolators/Switch Fuses/Changeover Switches  
**SURFACE & PANEL MOUNT**  
(20A - 1250A)







## ARE YOU SAFELY LOCKED OUT..?



# #motorcontrol #design #manufacture

OTHERS IN THE CROMPTON GROUP OF COMPANIES



Product in focus  
**Standard Starters**

# Star Delta Motor Starters

**22kW 43A FLC version  
 ref 3SD3ENS without isolator //**

**Standard Features:**

- IP55 Steel Enclosure 184H x 284W x 149D(mm)
- Built in Stop/Start push buttons
- Provision for Remote Control
- Hand Reset Thermal Overload
- Coil voltages 24V, 48V, 110V, 230V, 400V & 440V
- UK designed & manufactured



**Complete Star Delta starter range of products available**

LARGER Star Delta Standard Starters **11kW to 220kW**  
 Star Delta DC Injection Brakes **5.5kW to 37kW**  
 Customised Steel, Plastic/GRP, Stainless and ATEX enclosures on request



# Direct-on-Line Motor Starters

**7.5kW 18A FLC version  
 ref 3DL2EZS without isolator //**

**Standard Features:**

- IP55 Steel Enclosure
- Surface mounting (flush mounting option)
- Three phase (and single phase)
- Built in Stop/Start push buttons
- Provision for Remote Control
- Hand Reset Thermal Overload
- Coil voltages 24V, 48V, 110V, 230V, 400V & 440V
- UK designed & manufactured



**Complete DOL starter range of products available**

LARGER Size Direct-on-Line Standard Starters **5.5kW to 132kW**  
 Direct-on-Line DC Injection Brakes **2.2kW to 22kW**  
 Customised Steel, Plastic/GRP, Stainless and ATEX enclosures on request



Product in focus

# DC Injection Brake: Spingard

## EMERGENCY STOP SYSTEM FOR RADIAL DRILLING MACHINES

For Installation on all Radial Arm Drilling Machines

### APPLICATION

For automatic emergency stopping using the principle of timed DC Injection braking.

This system can be retro-fitted to existing machines bringing them in line with modern safety precautions.



### D.C. Injection Brake Units 'SPINGARD'

Including Trip Arm and Reset for Button Emergency Stopping of Spindle Drives

Motor Rating	Reference	List Price £	Motor Rating	Reference	List Price £	Motor Rating	Reference	List Price £
4kW (5.5hp)	3SG1S	830.00	7.5kW (10hp)	3SG2S	1,112.00	11kW (15hp)	3SG3S	1,370.50

Call us **NOW** for Technical Help and Pricing..!

# Partnership Matters

PARTNERSHIP MATTERS

**BEGE**  
POWER TRANSMISSION

[www.bege.nl/en](http://www.bege.nl/en)

## BEGE Power Transmission

Crompton Controls are the new and exclusive UK distribution partner for BEGE Power Transmission.

With high quality power and control products including all types of mechanical geared motors, drum motors, MIG encoders and much more BEGE specializes in driving industrial machines.

As reliable partners, we can help machine builders and end users to engineer and optimize their production processes with power transmission and control technology from a single source for smart and efficient automation solutions.

BEGE and Crompton: Power Transmission Under Complete Control.

See Pages 4 and 5

PARTNERSHIP MATTERS

**emotron**  
DEDICATED DRIVE  
A CG Product

[www.emotron.com](http://www.emotron.com)

## Emotron

Crompton Controls and Emotron have been in partnership for over two decades!

As Emotron's Number one UK distribution partner we deliver and support an outstanding range of power and industrial control products including Shaft Power Monitors, Electronic Soft Starters, Variable Speed Inverter Drives, Rotary Heat Exchanger Equipment along with matched Drive and Motor packages.

With our combined experience and expertise we can also create complete control systems optimised for your application to give the best performance and peace of mind.

Together, we put all our energy into saving yours!

See Pages 40 to 51

PARTNERSHIP MATTERS

**YASKAWA**

[www.yaskawa.co.uk](http://www.yaskawa.co.uk)

## Yaskawa

Crompton Controls are an authorised Yaskawa sales partner having worked together for well over 10 years.

Yaskawa have extensive knowledge and many years' experience in automation with more than 22 million AC drives installed worldwide. Thanks to high manufacturing quality and products designed for long, maintenance-free operation, we can offer highly competitive and reliable drive solutions for all industrial and machine control applications.

With well known legacy products from the J1000, V1000 and A1000 inverters to the latest state of the art GA500 and GA700 general purpose and industrial drives we can offer a comprehensive range of drive modules through to custom built inverter control panel solutions.

Yaskawa and Crompton Controls - AC Drives for all your industrial needs

See Pages 52 to 59

For more information contact our Technical Sales Team now  
[sales@cromptoncontrols.co.uk](mailto:sales@cromptoncontrols.co.uk) / **01924 368251**



# Why choose **Crompton** for your **Starters**

- **UK manufacturer with over 130 years history**
- **Huge Market** - for new & replacement starters & components
- **Largest Range** - of motor starters available from a single supplier
- **Experienced Sales & Technical Support Staff always on hand**
- **Custom Build** - Starters with any additional controls & features
- **Free Product & Sales Training** - for close stockist partners

**Get off to the right start..!**



## Direct-on-Line & Star Delta **Standard Motor Starters**

...and there's more...

## **BESPOKE**

WE'RE No.1 IN THE UK FOR OUR HUGE RANGE OF STANDARD GEAR FROM STOCK & WE RAISE THE BAR HIGHER STILL WITH OUR CUSTOM DESIGN & BUILD OFFERING. COVERING YOUR EXACT SPECIFICATION, WE'LL PLAN THROUGH YOUR NEEDS WITH YOU, OFFER ADVICE, CREATE POSSIBILITIES & DELIVER THE OPTIMAL SOLUTION FOR YOUR PROCESS OR APPLICATION - WHAT BITS DO YOU WANT IN YOUR BOX? YOU NAME IT, WE'LL CUSTOM BUILD IT!

For more on starters go to **Section 2**  
**Starters, Enclosures & Easy Speedy** (Page 14 to 21)



# UNDER CONTROL >>

FROM COMPONENTS TO STANDARD STARTERS TO COMPLETE BMS CONTROL PANEL SOLUTIONS



## Conditions of Sale

Goods are sold subject to our Standard Conditions of Sale appropriate to the particular goods (available on request).

Delivery Charges up to 20kg  
 Standard 1 to 2 day carrier under £50.00 list order value £9.00 net  
 Standard 1 to 2 day carrier over £50.00 list order value £15.00 net

Next Day up to 5.00pm	£ 21.50 net
Next Day up to 10.30am	£ 31.50 net
Next Day up to 12.00 noon	£ 26.50 net
Saturday am	£ P.O.A.
Items over 20kg	£110.00 net per pallet

Northern Ireland and Scottish Highlands £26.50 up to 3 days transit.  
 - no next day service.

Southern Ireland, Channel Islands and Scottish Islands £38.50 up to 3 days transit.  
 - no next day service.

We can arrange special delivery via couriers etc. at customers request.  
 Note: Delivery charges for larger Inverters, Soft Starters, ATEX & Special Panels - P.O.A.

All prices are subject to VAT at the appropriate rate.

## SPECIALIST CONTROL SOLUTIONS

[www.cromptoncontrols.co.uk](http://www.cromptoncontrols.co.uk)

Crompton Controls, Monckton Road, Wakefield WF2 7AL

☎ +44 (0) 1924 368251  
 📠 +44 (0) 1924 367274  
 ✉ [sales@cromptoncontrols.co.uk](mailto:sales@cromptoncontrols.co.uk)



### Disclaimer:

Products offered may differ from those described in this publication due to later production, changes in specification, components, or manufacturing origin.

Our policy is one of constant development and improvement. Whilst every effort is made to make this catalogue accurate at the date of printing, specification and/or appearance may be changed in the interest of continuous improvement.

All products are subject to availability and are correct at the time of print.

Errors and omissions excepted.



All information contained in this publication is, as far as possible, correct at the time of going to print. However, due to our policy of continued improvement, we reserve the right to alter specifications without prior notice. © 2021 Crompton Controls.

All rights reserved.

[www.cromptoncontrols.co.uk](http://www.cromptoncontrols.co.uk)

