

DATASHEET

Data and signal protection ESP E Series

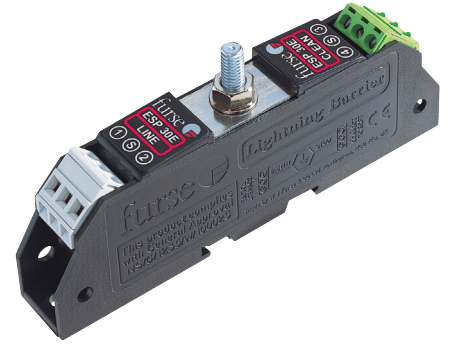

Combined Category D, C, B tested protector (to BS EN 61643) suitable for twisted pair signalling applications which require either a lower in-line resistance, an increased current or a higher bandwidth than the ESP D Series. Also suitable for DC power applications less than 1.25 Amps. Available for working voltages of up to 6, 15, 30, 50 and 110 Volts. For use at boundaries up to LPZ 0 to protect against flashover (typically the service entrance location) through to LPZ 3 to protect sensitive electronic equipment.



Features & benefits

- Very low let-through voltage (enhanced protection to IEC/BS EN 62305) between all lines - Full Mode protection
- Full Mode design capable of handling partial lightning currents as well as allowing continual operation of protected equipment
- Repeated protection in lightning intense environments
- Very low (1 Ω) in-line resistance allows resistance critical applications (e.g. alarm loops) to be protected
- High (1.25 A) maximum running current
- High bandwidth enables higher frequency (high traffic or bit rate) data communications
- Screen terminal enables easy connection of cable screen to earth
- Strong, flame retardant, ABS housing
- Built-in DIN rail foot for simple clip-on mounting to top hat DIN rails
- Colour coded terminals give a quick and easy installation check - grey for the dirty (line) end and green for clean
- Substantial earth stud to enable effective earthing
- Supplied ready for flat mounting on base or side
- Integral earthing plate for enhanced connection to earth via CME kit
- ESP 06E and ESP 15E have Network Rail Approval PA05/02047. NRS PADS reference 086/000201 (ESP 06E) and 086/000200 (ESP 15E)

Installation

Connect in series with the data communication or signal line either near where it enters or leaves the building or close to the equipment being protected (e.g. within its control panel). Either way, it must be very close to the system's earth star point. Install protectors either within an existing cabinet/cubicle or in a separate enclosure.

Application

Use these units to protect resistance sensitive, higher frequency or running current systems, e.g. high speed digital communications equipment or systems with long signal lines.

Accessories

Combined Mounting/Earthing kits:

CME 4 Mount & earth up to 4 protectors

CME 8 Mount & earth up to 8 protectors

CME 16 Mount & earth up to 16 protectors

CME 32 Mount & earth up to 32 protectors

Weatherproof enclosures:

WBX 2/G

For use with up to 2 protectors

WBX 3, WBX 3/G

For use with up to 3 protectors

WBX 4, WBX 4/GS

For use with a CME 4 and up to 4 protectors

WBX 8, WBX 8/GS

For use with a CME 8 and up to 8 protectors

WBX 16/2/G

For use with one or two CME 16 and up to 32 protectors

Install in series (in-line)

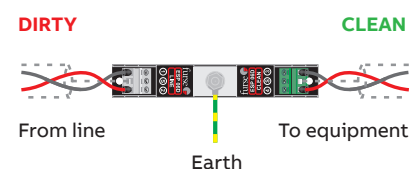

NOTE: Slim Line (ESP SL), ATEX (ESP SLX) and PCB mount (ESP PCB) are available. For many twisted pair data and signal applications, the lower cost ESP D Series may be suitable. For applications requiring higher current (1.25 A to 4 A) or ultra-low in-line resistance, the ESP H Series protectors may be more suitable. For data and signal lines on LSA-PLUS modules, use the ESP KS Series.

ESP E Series - Technical specification

Electrical specification	ESP 06E	ESP 15E	ESP 30E	ESP 50E	ESP 110E
ABB order code	7TCA085400R0084	7TCA085400R0095	7TCA085400R0104	7TCA085400R0116	7TCA085400R0007
Nominal voltage ⁽¹⁾	6 V	15 V	30 V	50 V	110 V
Maximum working voltage U_c (RMS/DC) ⁽²⁾	5 V / 7.79 V	11 V / 16.7 V	25 V / 36.7 V	40 V / 56.7 V	93 V / 132 V
Current rating (signal)	1.25 A				
In-line resistance (per line $\pm 10\%$)	1.0 Ω				
Bandwidth (-3 dB 50 Ω system)	45 MHz				
Transient specification	ESP 06E	ESP 15E	ESP 30E	ESP 50E	ESP 110E
Let-through voltage (all conductors)⁽³⁾ Up					
C2 test 4 kV 1.2/50 μ s, 2 kA 8/20 μ s to BS EN/EN/IEC 61643-21	36.0 V	39.0 V	60.0 V	86.0 V	180 V
C1 test 1 kV, 1.2/50 μ s, 0.5 kA 8/20 μ s to BS EN/EN/IEC 61643-21	26.2 V	28.0 V	49.0 V	73.5 V	170 V
B2 test 4 kV 10/700 μ s to BS EN/EN/IEC 61643-21	16.0 V	25.5 V	43.5 V	65.0 V	160 V
5 kV, 10/700 μ s ⁽⁴⁾	17.0 V	26.2 V	44.3 V	65.8 V	165 V
Maximum surge current					
D1 test 10/350 μ s to BS EN/EN/IEC 61643-21: - Per signal wire	2.5 kA				
	- Per pair	5 kA			
8/20 μ s to ITU-T K.45:2003, - Per signal wire	10 kA				
IEEE C62.41.2:2002: - Per pair	20 kA				
Mechanical specification	ESP 06E	ESP 15E	ESP 30E	ESP 50E	ESP 110E
Temperature range	-40 to +80 °C				
Connection type	Screw terminal - maximum torque 0.5 Nm				
Conductor size (stranded)	2.5 mm ²				
Earth connection	M6 stud				
Case material	FR Polymer UL-94 V-0				
Weight: - Unit	0.08 kg				
Dimensions	See diagram below				

- ⁽¹⁾ Nominal voltage (RMS/DC or AC peak) measured at < 10 μ A (ESP 15E, ESP 30E, ESP 50E, ESP 110E) and < 200 μ A (ESP 06E)
- ⁽²⁾ Maximum working voltage (RMS/DC or AC peak) measured at < 5 mA leakage (ESP 15E, ESP 30E, ESP 50E, ESP 110E) and < 10 mA (ESP 06E)
- ⁽³⁾ The maximum transient voltage let-through of the protector throughout the test ($\pm 10\%$), line to line & line to earth, both polarities. Response time < 10 ns
- ⁽⁴⁾ Test to IEC 61000-4-5:2006, ITU-T (formerly CCITT) K.20, K.21 and K.45, Telcordia GR-1089-CORE, Issue 2:2002, ANSI TIA/EIA/IS-968-A:2002 (formerly FCC Part 68)

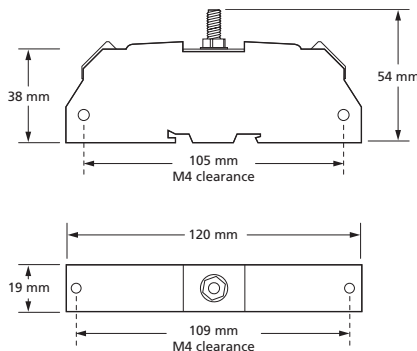

ABB order codes

Part	ABB order code	Part	ABB order code	Part	ABB order code
CME4	7TCA085400R0001	CME8	7TCA085400R0002	CME16	7TCA085410R0002
CME32	7TCA085410R0003	WBX 2/G	7TCA085410R0022	WBX 3	7TCA085410R0023
WBX 3/G	7TCA085410R0024	WBX 4	7TCA085410R0027	WBX 4/GS	7TCA085410R0028
WBX 8	7TCA085410R0030	WBX 8/GS	7TCA085410R0031	WBX 16/2/G	7TCA085410R0020