

ABS IP65 ENCLOSURES

IP65 Enclosures

Watertight Smooth Wall Enclosure

Grey watertight ABS plastic electronics enclosures ideally suited for mounting electronic circuit board or DIN mounted components in eighteen different sizes. There are internal PCB mounting pillars on the base of the enclosure. The enclosure lids are fixed by four universal cross cut head machine screws (supplied). The material ABS used in manufacture is Halogen free and glow wire tested to IEC 60695-2-11.

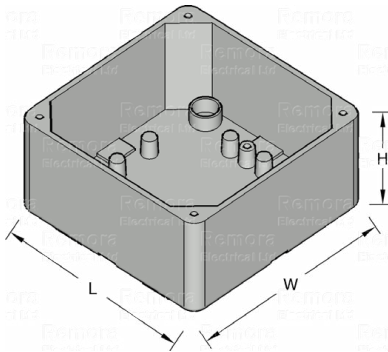

ABS Enclosure

- Manufactured from strong/lightweight ABS material
- Captive steel or polymer screws with universal cross/cut head
- Double insulation
- Pressure tested in accordance with CEI 23-48: 70°C
- Shock resistance: IK08 IP55, IP65

Protection: IP55 / IP65

Temperature Range: -5°C to 60°C

Enclosure Material: Halogen Free ABS Techno-polymer

Gasket Material: EPDM

Glow Wire Test: 650°C IEC 60695-2-11PDM

Ageing Test Accordance: CEI 23-48:7 days at 70°C

Colour: Grey RAL7035



Dimensions

Code	Length (L)	Width (W)	Height (H)	Colour
ABS1305560	130	55	60	Grey
ABS10010060	100	100	60	Grey
ABS1309065	130	90	65	Grey
ABS15011075	150	110	75	Grey
ABS15014075	150	140	75	Grey
ABS19014075	190	140	75	Grey
ABS17017075	170	170	75	Grey
ABS170170128	170	170	128	Grey
ABS24019090	240	190	90	Grey
ABS190140140	190	140	140	Grey
ABS310240100	310	240	100	Grey
ABS250195100	250	195	100	Grey
ABS240190120	240	190	120	Grey
ABS310240120	310	240	120	Grey
ABS380300120	380	300	120	Grey
ABS380300180	380	300	180	Grey
ABS460380120	460	380	120	Grey
ABS460380120	460	380	120	Grey