



IP65 Enclosures

Watertight Smooth Wall Enclosure

Grey watertight ABS plastic electronics enclosures with clear top to take electronic circuit boards in fourteen different sizes. There are internal PCB mounting pillars on the base of the enclosure. The enclosure lids are fixed by four universal cross cut head machine screws (supplied). The material ABS used in manufacture is Halogen free and glow wire tested to IEC 60695-2-11.

Transparent Lid ABS Enclosure

- Manufactured from strong/lightweight ABS material
- Captive steel or polymer screws with universal cross/cut head
- Double insulation
- Pressure tested in accordance with CEI 23-48: 70°C
- Shock resistance: IK08 IP55, IP65

Protection: IP55 / IP65

Temperature Range: -5°C to 60°C

Enclosure Material: Halogen Free ABS Techno-polymer

Gasket Material: EPDM

Glow Wire Test: 650°C IEC 60695-2-11PDM

Ageing Test Accordance: CEI 23-48:7 days at 70°C

Colour: Grey RAL7035 / Transparent Lid

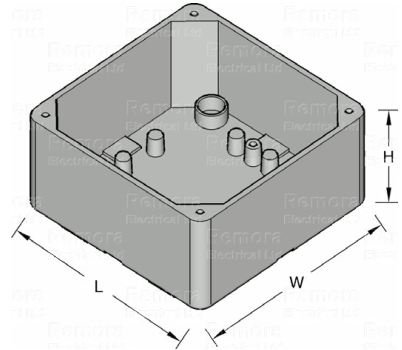

Dimensions

Transparent Lid	Length (L)	Width (W)	Height (H)	Colour
ABS-TL15011075	150	110	75	Grey
ABS-TL15014075	150	140	75	Grey
ABS-TL19014075	190	140	75	Grey
ABS-TL17017075	170	170	75	Grey
ABS-TL170170128	170	170	128	Grey
ABS-TL24019090	240	190	90	Grey
ABS-TL190140140	190	140	140	Grey
ABS-TL310240100	310	240	100	Grey
ABS-TL240190120	240	190	120	Grey
ABS-TL310240120	310	240	120	Grey
ABS-TL380300120	380	300	120	Grey
ABS-TL380300180	380	300	180	Grey
ABS-TL460380120	460	380	120	Grey
ABS-TL460380180	460	380	180	Grey