

Dual-Fixing

Plastic Two-Part Dual-Fixing

Standard Polypropylene
LSZH Polypropylene

The TC Two Hole Cable Clamps are a range of two hole fixing, two part cleats designed to fit cables 41mm to 135mm diameter. Manufactured from high strength polypropylene and designed to be easily stacked to save time and space.



Dual Fixing - Plastic

- Fastening/fitting/routing single and multiple conductor low, medium and high voltage cables
- Excellent weathering and high resistance to ultraviolet light
- Excellent stiffness
- Excellent tensile strength
- Fully recyclable
- Underwriters Laboratories UL94-V0
- Zero Halogen material (LSZH Polypropylene)

Standards: European Standard IEC 61914:2009

Temperature Range: -40°C to 40°C

Material: Polypropylene / LSZH Polypropylene

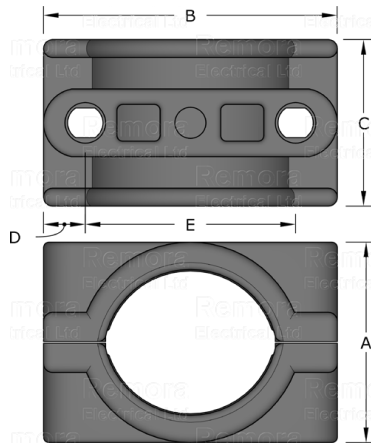

Standard Code	Red Code	Low Smoke Code	Cable Range		Stud Hole Size	Dimensions				
			Min	Max		(A)	(B)	(C)	(D)	(E)
TC8	TC8-RED	TC8LS	41.0	48.0	2 x M10	62.0	97.0	58.0	12.0	75.0
TC9	TC9-RED	TC9LS	48.0	57.0	2 x M10	64.0	99.0	59.0	13.0	76.2
TC10	TC10-RED	TC10LS	57.0	64.0	2 x M10	70.0	104.0	59.0	15.0	76.2
TC11	TC11-RED	TC11LS	64.0	70.0	2 x M10	81.0	134.0	63.0	12.0	114.3
TC12	TC12-RED	TC12LS	70.0	76.0	2 x M10	87.0	135.0	63.0	12.0	114.3
TC14	TC14-RED	TC14LS	76.0	85.0	2 x M10	93.0	135.5	63.0	12.0	114.3
TC15	TC15-RED	TC15LS	85.0	105.0	2 x M10	108.0	179.0	74.0	17.0	147.0
TC16		TC16LS	105.0	112.0	2 x M10	130.0	161.0	54.0	13.0	135.0
TC17		TC17LS	112.0	120.0	2 x M10	138.0	169.0	54.0	13.0	143.0
TC18		TC18LS	120.0	128.0	2 x M10	148.0	177.0	54.0	13.0	151.0
TC19		TC19LS	128.0	135.0	2 x M10	158.0	185.0	54.0	13.0	158.0